



# CHELICHANA

PRODUCT CATALOGUE

2025

A black and white photograph of a gym machine, possibly a leg press or similar, with various tools and parts scattered on the floor in front of it. The machine has a large, padded seat and a handle with the brand name 'STELICMAN' visible. The background shows other gym equipment, including treadmills, in a dimly lit setting. The overall mood is industrial and focused on engineering and maintenance.

*Where engineering meets passion.*



# Table of Contents

**ABOUT US**

---

**LOWER BODY**

---

**UPPER BODY**

---

**BENCHES**

---

**CAGES**

---

**CAGE ATTACHMENTS**

---

**STORAGES**

---

**WEIGHTS**

---

**BARBELLS**

---

**DUMBELLS**

---

**KETTLEBELLS**

---

**FUNCTIONAL EQUIPMENT**

---

**CARDIO**

---

**FLOORS**

---

**APPAREL**

---

**OUTDOOR**

---

**CHELICHANA**

*In Chelichana we're not just building equipment;  
we're crafting experiences.*

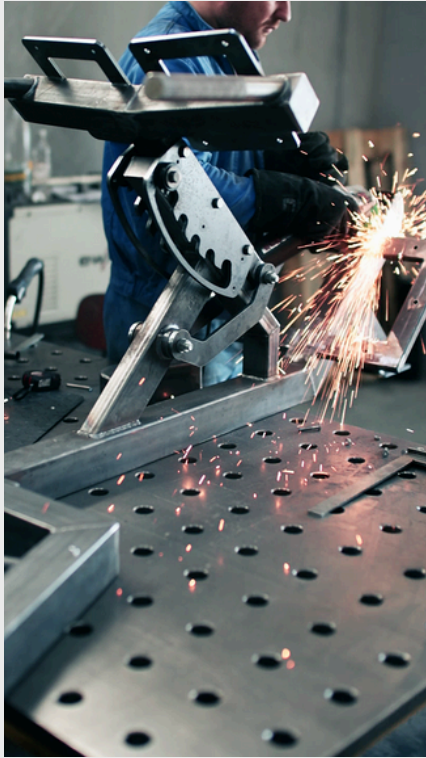

## WHO WE ARE

With 20 years of unparalleled experience, we've helped gyms, studios, and home users across the globe achieve their fitness goals through cutting-edge, high-performance products. Thanks to our background in manufacturing and our deep understanding of the strength community, we can offer quality, highly customizable strength equipment for indoor and outdoor spaces.

From conceptualization to production, we carefully craft each piece to exceed the most demanding standards, earning us a reputation as a trusted partner for fitness enthusiasts and wellness professionals.

Driven by a passion for fitness and a dedication to customer satisfaction, we continue to push the boundaries of what's possible, delivering innovative solutions that enhance athletic performance and improve quality of life.

BUILDING A STRONG, PROPORTIONAL LOWER BODY HAS NEVER BEEN EASIER. OUR STATE-OF-THE-ART MACHINES ARE ENGINEERED TO HELP YOU SCULPT SHAPELY GLUTES, POWERFUL QUADS, AND MASSIVE CALVES.



# LOWER body



CH-D01

## LEG EXTENSION 2.0

108 KG  
141 cm x 150 cm x 125 cm

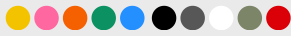

CH-D02

## LEG FLEXION

141 KG  
188 cm x 180 cm x 90 cm



CH-D55

## UNILATERAL LEG CURL

139 KG  
193 cm x 114 cm x 93 cm



CH-D46

## EXTENSION - FLEXION III

105 KG  
105 cm x 130 cm x 120 cm

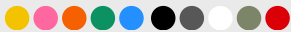

CH-D59

## COMBO EXTENSION- FLEXION

119 KG  
185 cm x 131 cm x 136 cm



CH-D05

## SEATED CALF 3.0

79 KG  
150 cm x 67 cm x 90 cm

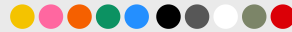

CH-D07

## LEG PRESS

208 KG  
220 cm x 112 cm x 157 cm



CH-D09

## HACK SQUAT

229 KG  
225 cm x 115 cm x 140 cm



CH-D44

## LEVERAGE LEG PRESS

225 KG  
200 cm x 153 cm x 147 cm

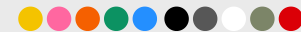



Ergonomic pads

# LEG EXTENSION



Adjustable back pad

Integrated handles

ANTI-SLIP GRIP



6 LEVEL  
ADJUSTABLE

PLATE LOADED

Target your quads with our plate loaded leg extension. Both arms move independently to ensure you improve strength in both legs equally.

Works the hamstrings, safeguarding the lower back thanks to the ergonomic incline of the pad..

# UNILATERAL LEG CURL

NATURAL MOTION CURVE

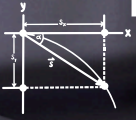

ENHANCED BIOMECHANICS

Angled torso support for comfort even under heavy loads.



ERGONOMIC DESIGN

6 level adjustable roller for reduced stress on the knee

handgrip

Heavy - duty steel frame

Adjustable zero position

PLATE LOADED

MINIMIZES LOWER-BACK STRESS

Unilateral Leg Curl minimizes strain on your joints and ensures proper alignment, reducing the chance of injury during hamstring exercises



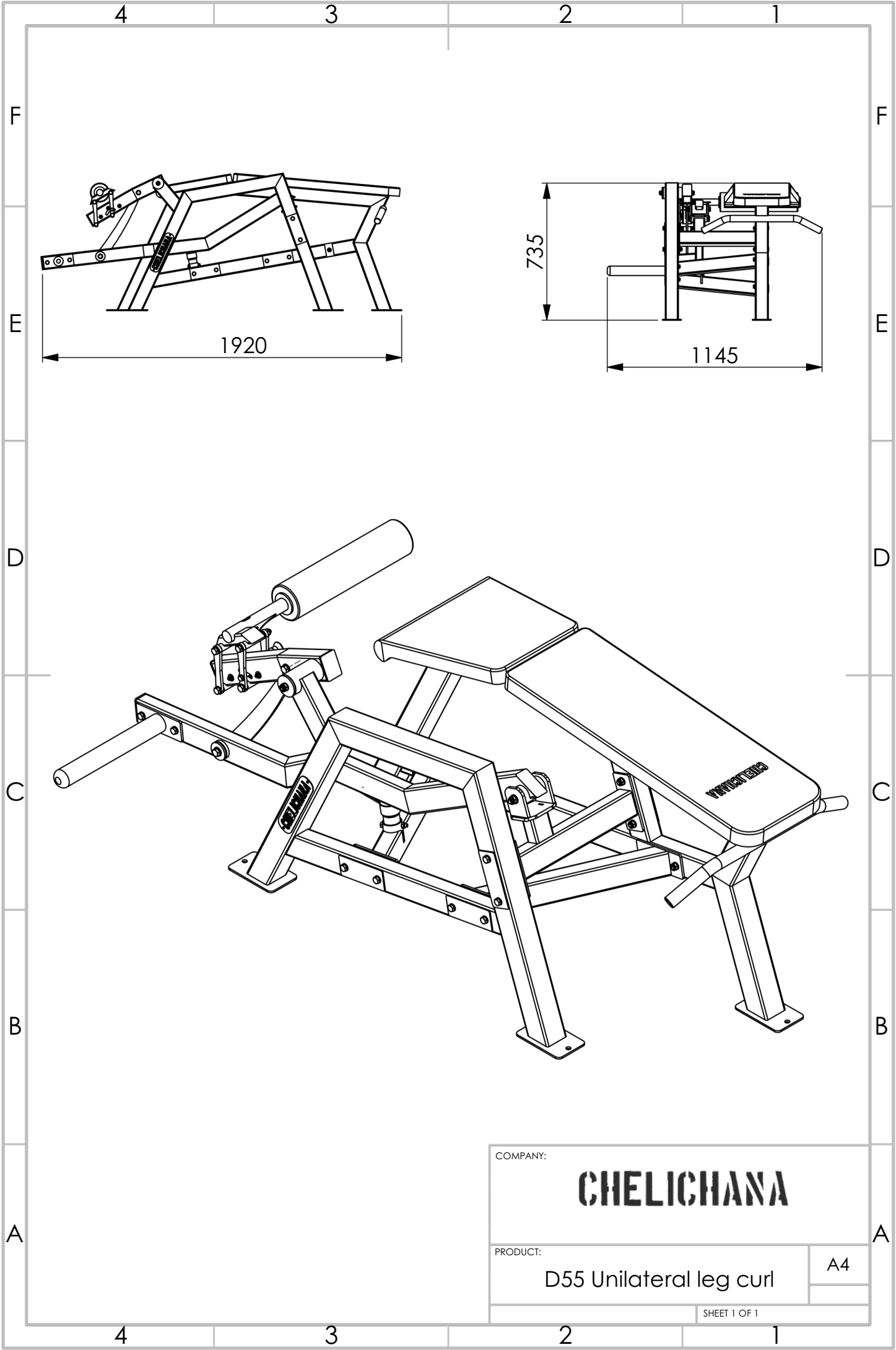

COMPANY:		<b>CHELICHANA</b>	
PRODUCT:		D55 Unilateral leg curl	A4
		SHEET 1 OF 1	



LARGE NON-SLIP FOOT PLATE



# LEVERAGE LEG PRESS



Comfortable padding

Integrated handles

Extra Heavy duty construction

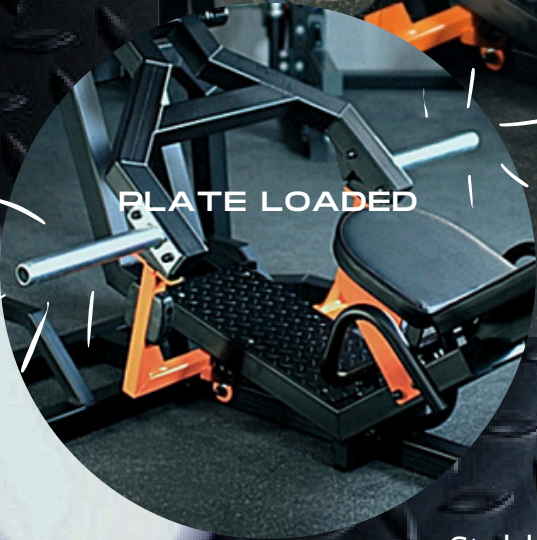

PLATE LOADED

Stable and ergonomic design protects knees, lower back, and joints from impact stress



CH-D13

## STANDING LEG CURL 2.0

50 KG  
93 cm x 94 cm x 110 cm



CH-D45

## SUPER SQUAT

189 KG  
212 cm x 145 cm x 166 cm



CH-D33

## PENDULUM SQUAT

189 KG  
235 cm x 188 cm x 120 cm



CH-D15

## REVERSE HYPEREXTENSION

97 KG  
140 cm x 95 cm x 130 cm

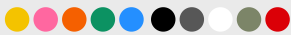

CH-D14

## GLUTE - HAM DEVELOPER 2.5

95 KG  
168 cm x 110 cm x 118 cm



CH-D30

## HYPER GHD

149 KG  
215 cm x 93 cm x 147 cm



CH-D16

## FLOOR GHD

46 KG  
127 cm x 53 cm x 70 cm

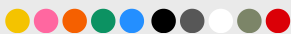

CH-D17

## SINGLE LEG SQUAT STAND

24 KG  
54 cm x 61 cm x 63 cm



CH-D52

## GLUTE BRIDGE

140 KG  
182 cm x 141 cm x 73 cm



ergonomic pad

Oversized angled foot platform to accommodate users of all sizes

# GLUTE BRIDGE

Adjustable backrest

plate loaded

The pull-pin quick lock and release mechanism simplifies the workout process.

INTEGRATED HANDBRAKE

Adjustable position

The **Glute Bridge** gives you the full benefits of the hip thrust exercise, simply, safely, and with biomechanically optimised weight curve.

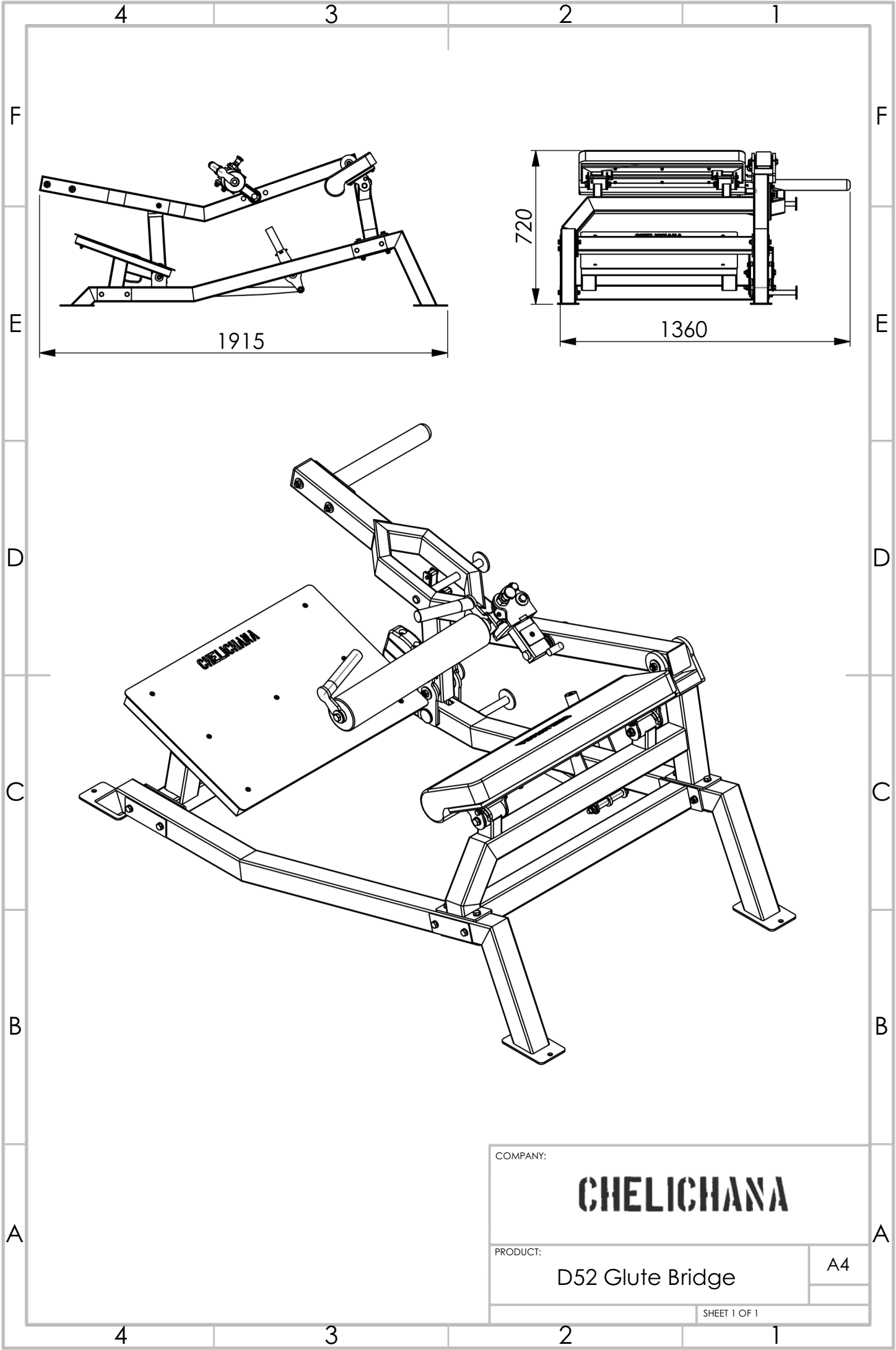

COMPANY:  
**CHELICHANA**

PRODUCT:  
D52 Glute Bridge

A4

SHEET 1 OF 1



CH-D18

### CALF BLOCK

6.4 KG  
64 cm x 40 cm x 14 cm

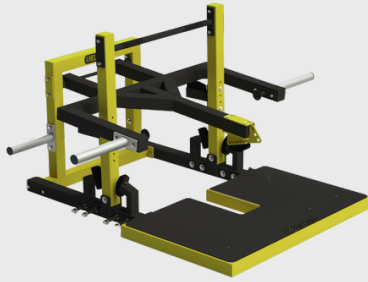

CH-D35

### BELT SQUAT

149 KG  
162 cm x 193 cm x 119 cm



CH-D41

### BELT SQUAT 2.0

101 KG  
171 cm x 100 cm x 103 cm



CH-D24

### GLUTE BUILDER

109 KG  
225 cm x 152 cm x 40 cm

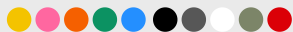

CH-D23

### HIP THRUSTER 2.0

49 KG  
149 cm x 78 cm x 43 cm



CH-D20

### MINI SLED

17 KG  
80 cm x 54 cm x 41 cm



CH-D19

### DOG SLED

45 KG  
103 cm x 98 cm x 61 cm



CH-D21

### PROWLER

39 KG  
124 cm x 105 cm x 112 cm



CH-D22

### YOKE 2.0

82 KG  
179 cm x 127 cm x 242 cm



BELT INCLUDED

ANTI-SLIP GRIP

# BELT SQUAT

Hand rail for support while performing exercise

HEAVY DUTY  
CONSTRUCTION

3 Adjustable height  
start positions

ANTI-SLIP FOOTPLATE

RUBBER STOPPER

transfers the weight load from your neck, back, and shoulders to your hips with the nylon belt

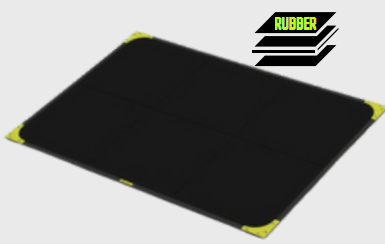

CH-D25

## DL PLATFORM 3X2M R

149 KG  
210 cm x 310 cm x 3 cm



CH-D35

## DL PLATFORM 3X2M R+W

129 KG  
210 cm x 310 cm x 3 cm

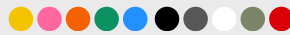

CH-D27

## DL PLATFORM 2.5X1M R

70 kg  
110 cm x 260 cm x 3 cm

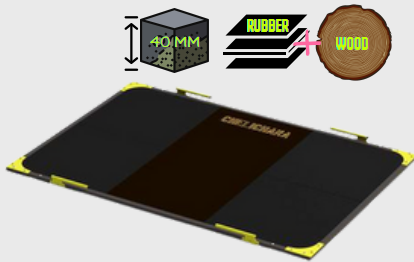
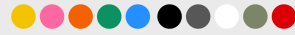

CH-D36

## PREMIUM PLATFORM 40MM

219 KG  
210 cm x 310 cm x 8 cm

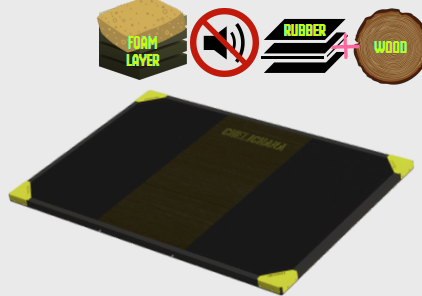

CH-D53

## SVR PLATFORM 80MM

430 KG  
213 cm x 313 cm x 8 cm



CH-D28

## STEP UP PLATFORM ADJUSTABLE

19 KG  
44 cm x 44 cm x 42 cm



CH-D39

## BOX SET

94 KG  
67 cm x 67 cm x 90 cm

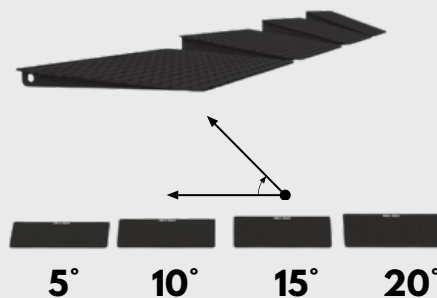

CH-D40

## SQUAT RAMP SET

19 KG  
76 cm x 31 cm x 9 cm

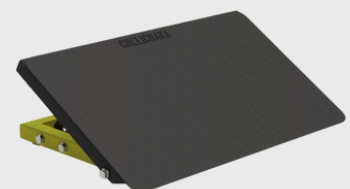

CH-D48

## SQUAT WEDGE

19 KG  
76 cm x 31 cm x 9 cm



Adjustable ergonomic  
leg pad

ADJUSTABLE GRIP  
POSITION

# DEADLIFT MACHINE

Knurled multigrip  
handles

Compact design

Improved  
biomechanics



PLATE LOADED

Multifunctional machine for training trapezius,  
glutes, and hamstrings.

# LOWER BODY



CH-D50

## DEADLIFT MACHINE

109 KG  
152 cm x 152 cm x 65 cm

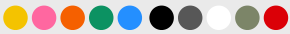

CH-D56

## DONKEY CALF RAISE

205 KG  
156 cm x 62 cm x 165 cm

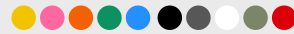

CH-D58

## MICRO SLED

5 KG  
60 cm x 26 cm x 28 cm



CH-D43

## SISSY SQUAT

33 KG  
99 cm x 73 cm x 50 cm

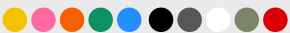

CH-D60

## ROW STAND

25 KG  
66 cm x 64 cm x 35 cm



STOP SETTling FOR A WEAK, UNDERDEVELOPED UPPER BODY. EXPLORE  
OUR UPPER BODY MACHINES AND BUILD POWERFUL PHYSIQUE YOU'VE  
ALWAYS WANTED.

**UPPER**  
body





CH-G31

## CROSTRAINER 2.5

464 KG  
110 cm x 215 cm x 237 cm



CH-G37

## LAT & PULLEY PLATE-LOADED 2.0

89 KG  
145 cm x 110 cm x 233 cm



CH-G27

## LAT & PULLEY 2.0

199 KG  
159 cm x 111 cm x 233 cm



CH-G01

## DUAL CABLE LAT MACHINE

210 KG  
131 cm x 111 cm x 230 cm

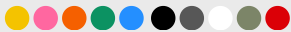

CH-G02

## DUAL CABLE PULLEY

224 KG  
237 cm x 111 cm x 230 cm

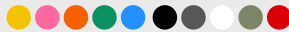

CH-G14

## ADJUSTABLE PULLEY 2.5

209 KG  
116 cm x 78 cm x 237 cm



CH-G08

## SEATED CHEST PRESS

161 KG  
200 cm x 186 cm x 113 cm



CH-G07

## SEATED ROW

119 KG  
141 cm x 143 cm x 109 cm



CH-G04

## CHEST SUPPORTED T-BAR ROW

70 KG  
191 cm x 112 cm x 126 cm





This plate-loaded row machine maximizes your range of motion to strengthen your back, improve posture, and build upper body muscle mass.

# SEATED ROW

Flexible adjustable handles



Stable seated design

Padded chest support

Plate loaded

Sturdy construction

ADJUSTABLE SEAT



It provides a stable and supported platform for performing a rowing motion while keeping your back straight and core engaged.

# CHEST SUPPORTED T-BAR ROW



ERGONOMIC DESIGN



Flexible adjustable handles

360°

Padded chest support

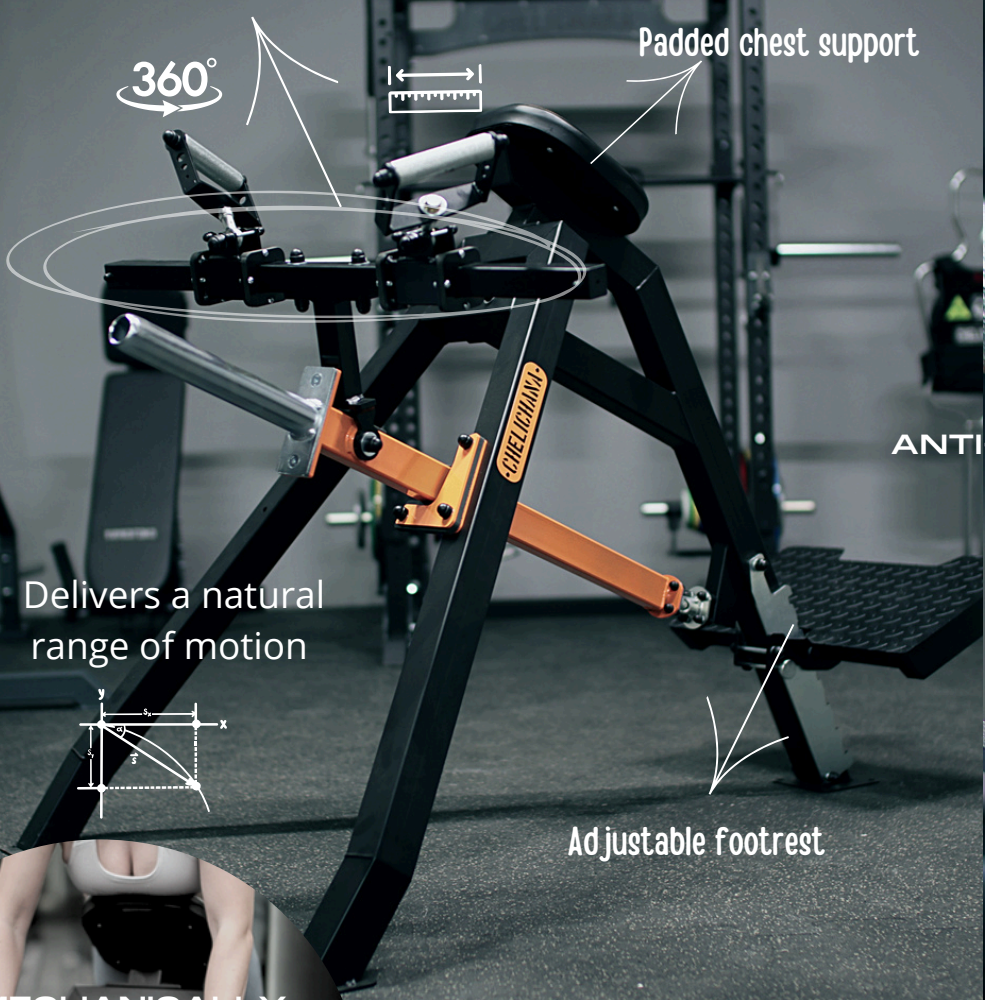

Delivers a natural range of motion

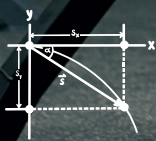

Adjustable footrest

ANTI-SLIP GRIP



BIOMECHANICALLY OPTIMISED



360 degree rotation technology to minimize the stress put on the connective tissue within the wrists, shoulders, and elbows



4

3

2

1

F

F

E

E

D

D

C

C

B

B

A

A

4

3

2

1

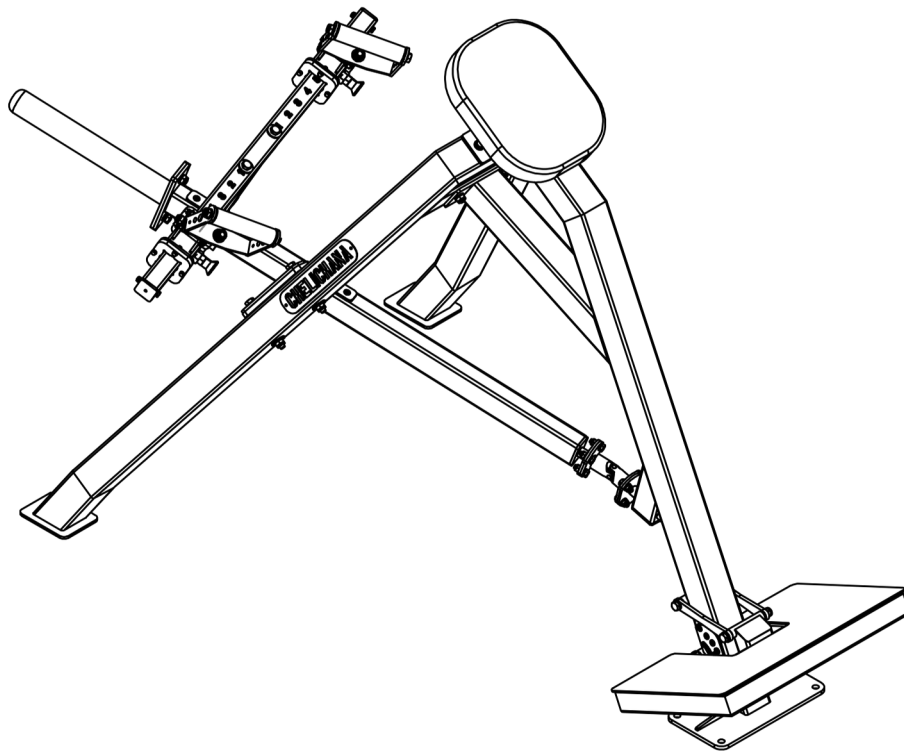
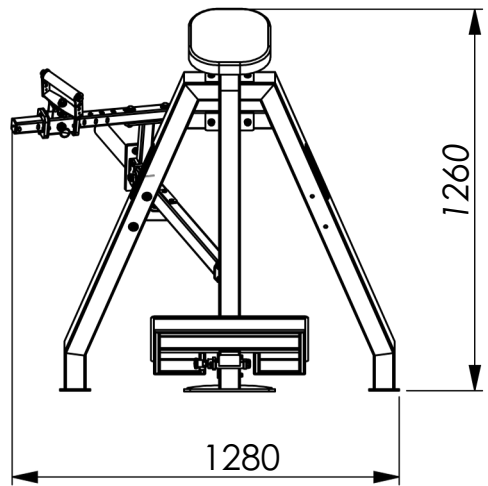
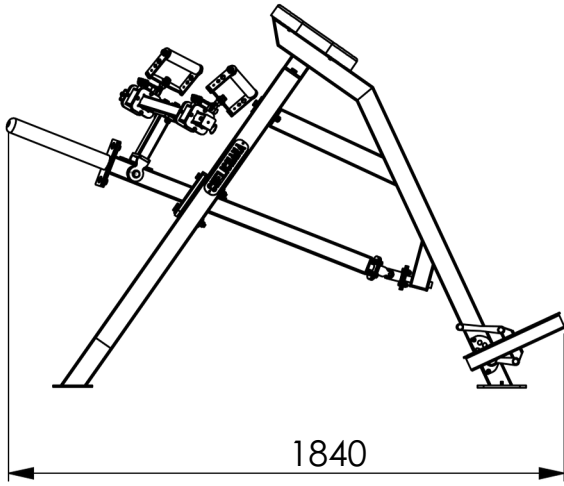

COMPANY:

**CHELICHANA**

PRODUCT:

G04 Chest Supported  
T-Bar Row

A4

SHEET 1 OF 1

# TRICEPS KICKBACK



This versatile machine lets you perform triceps dips and kick-backs all in one place.



CH-G40

### LEG RAISE 2.0

65 KG  
144 cm x 70 cm x 164 cm



CH-G41

### POWER TOWER 2.0

56 KG  
143 cm x 65 cm x 145 cm



CH-G42

### POWER TOWER ASSISTED

229KG  
140 cm x 70 cm x 240 cm

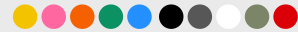

CH-G17

### STANDING DIPS

59 KG  
138 cm x 89 cm x 133 cm

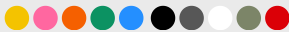

CH-G20

### TRICEPS KICKBACK

79 KG  
111 cm x 70 cm x 120 cm

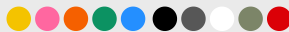

CH-G16

### HYPEREXTENSION 2.5

61 KG  
169 cm x 91 cm x 89 cm

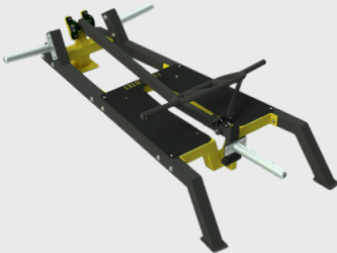

CH-G15

### T - BAR 2.0

89 KG  
192 cm x 112 cm x 53 cm



CH-G38

### SCOTT CURL

190 KG  
100 cm x 90 cm x 165 cm





Dual-action  
handlebars



Ergonomic back  
rest

# LEG RAISE



Upgradeable design



ANTI SLIP  
LEG STEP UP



KNURLED GRIP  
HANDLES

It provides a stable and supported platform for performing a rowing motion while keeping your back straight and core engaged.

Designed for improving abdominal, back and other core muscles.

# HYPEREXTENSION



comfortable ergonomic design



45 degree angle



6 level adjustable height



STURDY  
STABLE  
CONSTRUCTION

Space-saving design for easy integration into your gym or home

Textured foot platform to ensure secure positioning

LOWER ROLLER PADS  
INCREASE STABILIZATION  
AND COMFORT

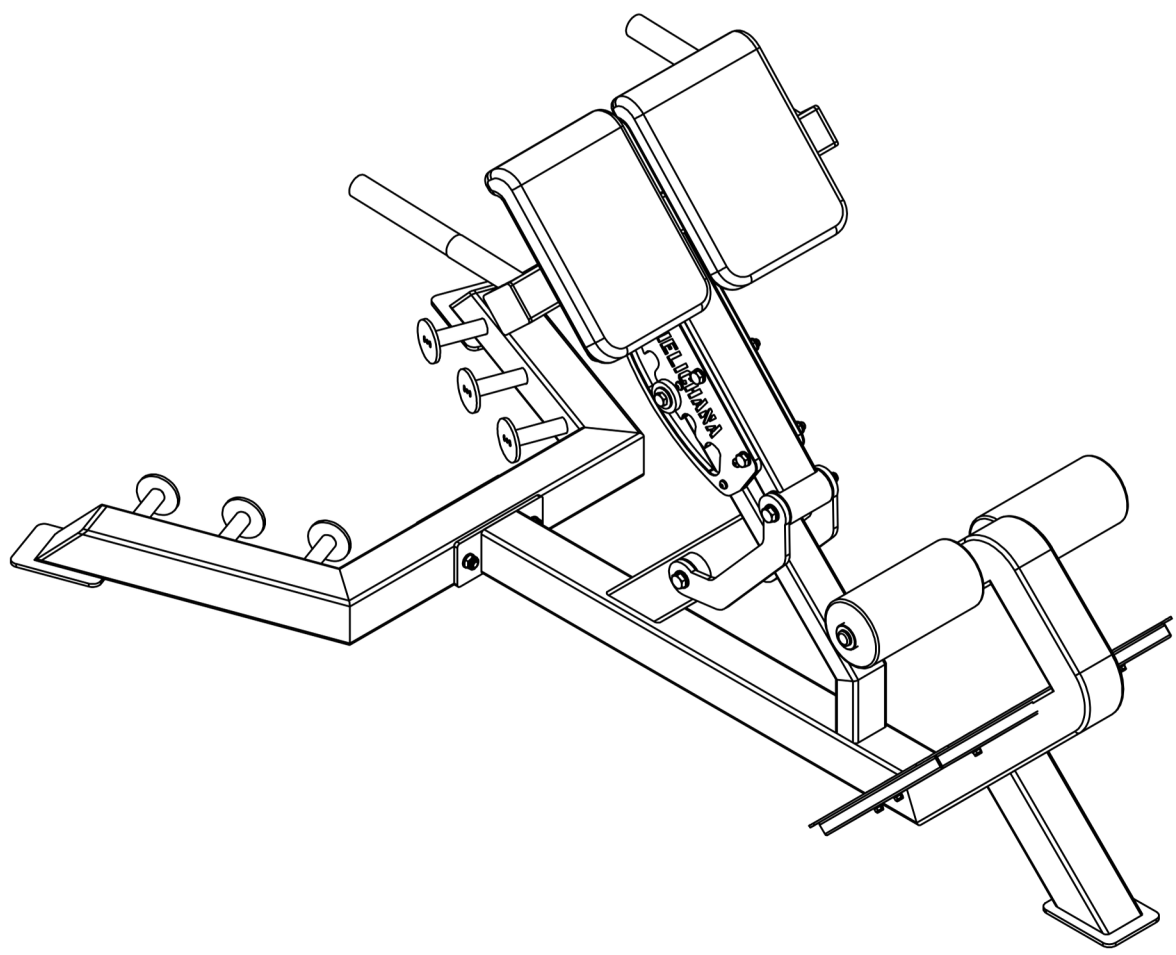
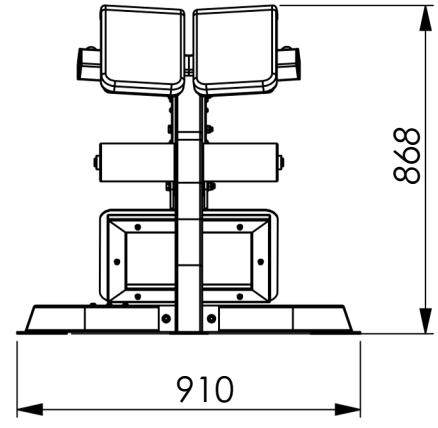
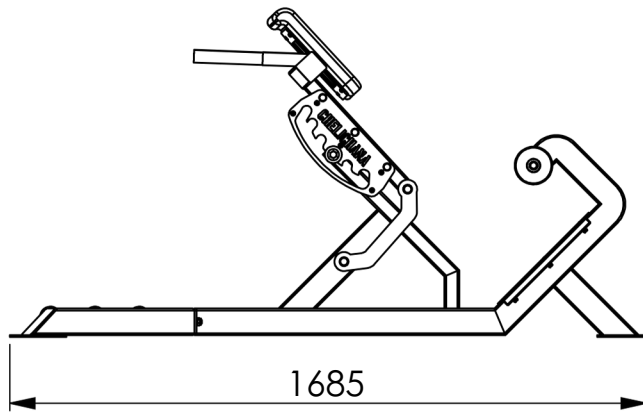

COMPANY:		<b>CHELICHANA</b>
PRODUCT:		
G16 Hyperextension		A4
		SHEET 1 OF 1



CH-G46

### SMITH MACHINE 3.0

153 kg  
158 cm x 220 cm x 221 cm

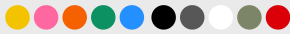

CH-G45

### SEATED SHOULDER PRESS

144 kg  
217 cm x 190cm x 125 cm



CH-G12

### CHEST FLY

95 kg  
149 cm x 135cm x 110 cm



CH-G39

### SEATED SHOULDER FLY

99 kg  
141 cm x 138 cm x 118 cm

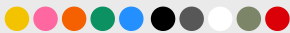

CH-G43

### SEATED REAR DELT

76 kg  
160 cm x 96 cm x 122 cm



CH-G47

### SEATED CHEST PRESS

172 kg  
185 cm x 153 cm x 135 cm

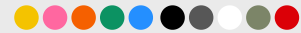

CH-MASET

### PREMIUM CABLE ATTACHMENT SET

15 kg  
88 cm x 56 cm x 15 cm

COMFORTABLE  
PADDING

# SEATED SHOULDER FLY

Plate loaded design

Ergonomic arm pads

Smooth  
movement curve

Compact design

Adjustable seat

ANTI-SLIP GRIP



Offers a pure and efficient range of motion that mirrors athletic movements, making it invaluable for improving shoulder strength, endurance, and injury resilience.

# SEATED REAR DELT

MULTI GRIP KNURLED HANDLES

Padded angled chest support

Flexible adjustable handles

PLATE LOADED

Compact stable design

ADJUSTABLE SEAT

Enhanced biomechanics



This Seated Rear Delt Machine isolates the posterior deltoid through a controlled motion path that mimics natural shoulder movement.





CH-G29

## ADJUSTABLE CABLE - PLATE LOADED

79 KG  
116 cm x 79 cm x 221 cm



CH-G22

## CABLE ATTACHMENTS - SET

11 KG  
120 cm x 15 cm x 26 cm



CH-G22A

## LAT PULL ATTACHMENT

3 KG  
120 cm x 15 cm x 3 cm



CH-G22B

## ROWING CABLE ATTACHMENT

3 KG  
69 cm x 17 cm x 7 cm



CH-G22C

## PARALLEL GRIP ATTACHMENT

2 KG  
25 cm x 17 cm x 16 cm



CH-G22D

## ONE HANDED CABLE ATTACHMENT

1 KG  
17 cm x 4 cm x 17 cm



CH-G22H

## MULTIGRIP ATTACHMENT

6 KG  
87 cm x 17 cm x 14 cm



CH-G22E

## STRAIGHT CABLE ATTACHMENT

2 KG  
46 cm x 4 cm x 7 cm



CH-G22K

## CABLE ATTACHMENT - EZ

4 KG  
74 cm x 3 cm x 15 cm



CH-G22F

### V CABLE ATTACHMENT

2 KG  
35 cm x 7 cm x 26 cm



CH-G22P

### CANNONBALL CABLE ATTACHMENT

0,4 kg  
4cm x 9 cm x 4 cm



CH-G22O

### DOGBONE CABLE ATTACHMENT

1,5 KG  
44 cm x 7 cm x 7 cm



CH-G23

### TUBE CABLE ATTACHMENT

3 KG  
4,5 x 21 x 4,5 cm



CH-G33

### DEADLIFT JACK

10 KG  
44 cm x 110 cm x 80 cm



CH-G23

### MINI DEADLIFT JACK

3 KG  
12 cm x 41 cm x 27 cm



MULTIFUNCTIONAL  
ADD ONS AND OPTIONS  
WITH POSSIBILITY TO  
TRAIN  
SIMULTANEOUSLY UP  
TO 8 PEOPLE

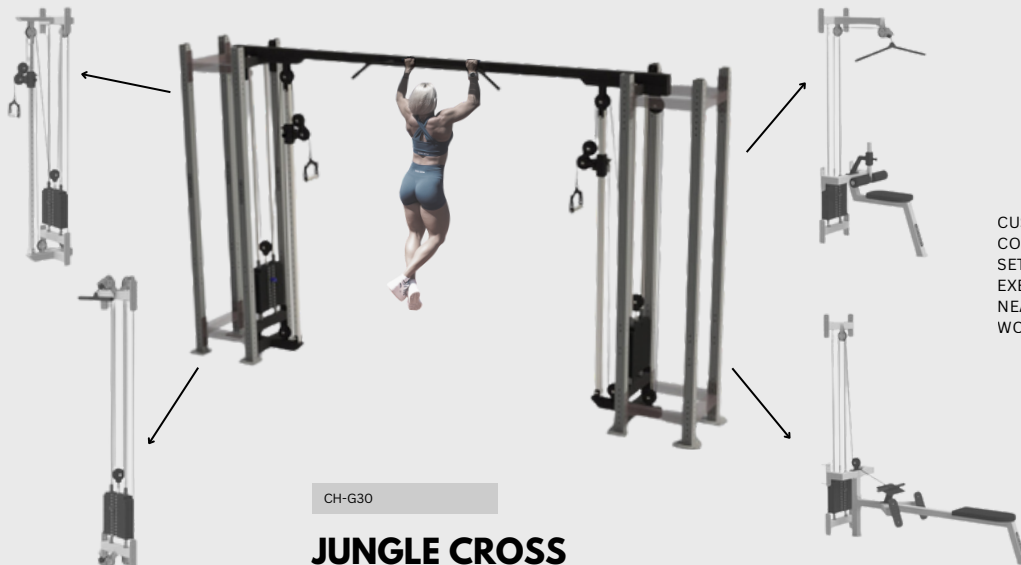

CUSTOM  
CONFIGURATIONS AND  
SETUPS TO PROVIDE  
EXERCISERS WITH  
NEARLY LIMITLESS  
WORKOUT VARIETY

CH-G30

### JUNGLE CROSS

492 KG  
425 cm x 70 cm x 248 cm



# BENCHES



CH-B02

## FLAT BENCH

19 KG  
130 cm x 78 cm x 45 cm

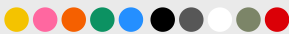

CH-B03

## VERTICAL BENCH

20 KG  
73 cm x 59 cm x 94 cm

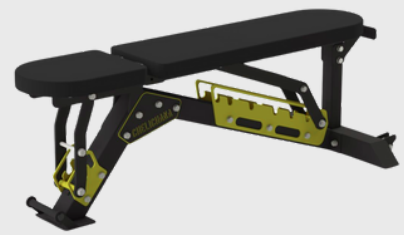

CH-B17

## ADJUSTABLE BENCH 3.0

42 KG  
131 cm x 57 cm x 45 cm



CH-B04

## MINI BENCH

12 KG  
52 cm x 44 cm x 45 cm



CH-B05

## SCOTT BENCH

59 KG  
90 cm x 99 cm x 102 cm



CH-B06

## AB BENCH

39 KG  
136 cm x 75 cm x 76 cm



CH-B07

## DECLINE ADJUSTABLE BENCH

59 KG  
148 cm x 80 cm x 70 cm



CH-B08

## BENCH PRESS - FLAT

75 kg  
174 cm x 124 cm x 135 cm



CH-B09

## INCLINE BENCH PRESS 2.0

79 KG  
145 cm x 124 cm x 143 cm



A versatile and robust addition to any home gym, designed to meet all your fitness needs. Whether you're performing dumbbell presses, seated curls, or any other strength training exercises, this bench offers exceptional stability and comfort.

MULTIPLE COLOR  
OPTIONS



# ADJUSTABLE BENCH



Space-saving design



only 30mm gap



7 level foldable backrest



3 level  
adjustable seat  
position



custom logo stitching



ADDED WHEELS AND  
TRANSPORT HANDLE  
FOR EASY  
MANOEUVRABILITY

COMFORTABLE AND  
ERGONOMIC



The closed ladder design keeps the ladder securely in place when adjusting the bench and when storing it vertically..

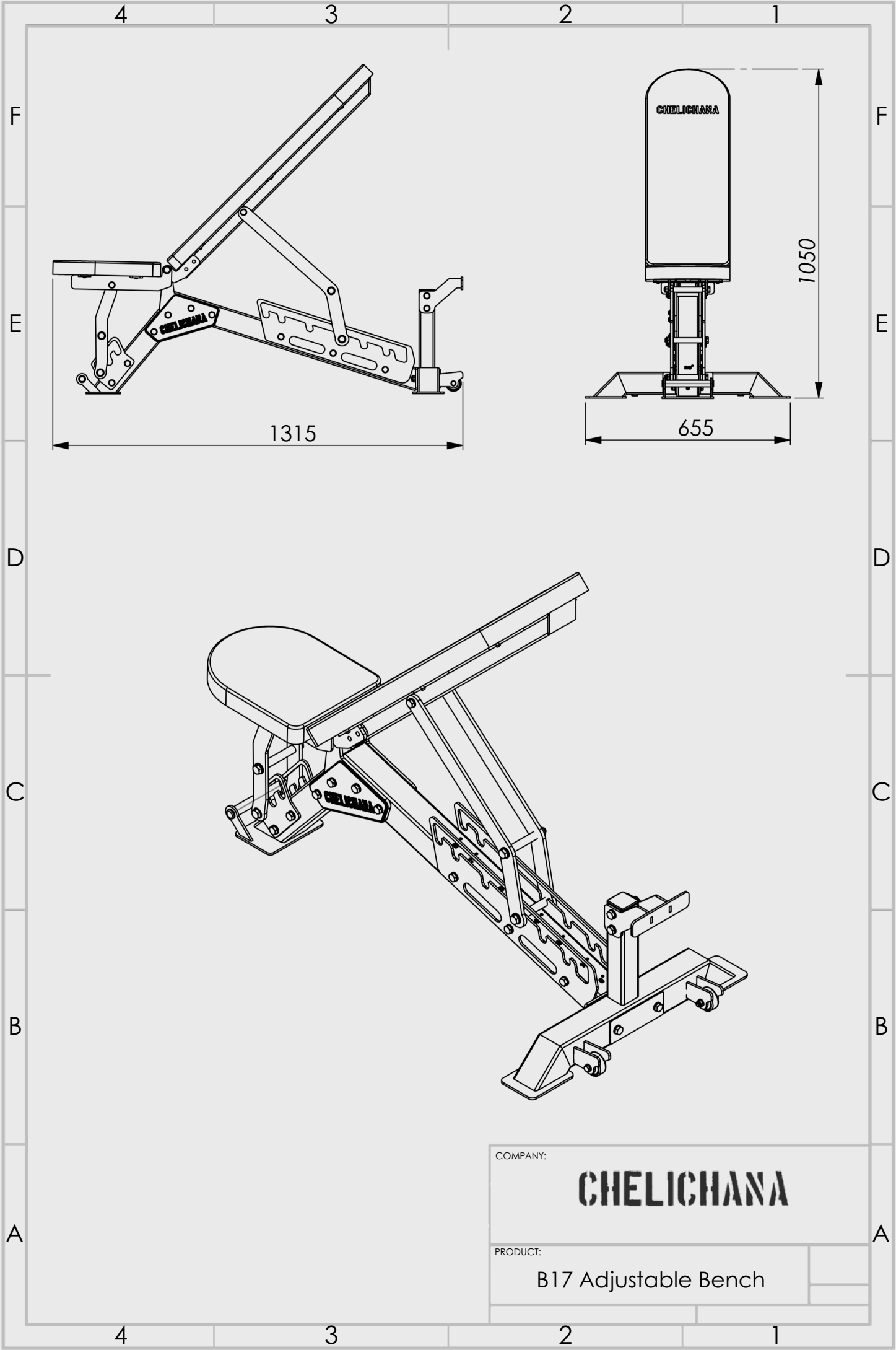

COMPANY:  
**CHELICHANA**

PRODUCT:  
B17 Adjustable Bench

adjustable spotter bar  
height

# COMBO BENCH

adjustable bench press  
J-hook height

HEIGHT  
REGULATOR  
LEVER

sturdy construction

2IN1  
DETACHABLE  
DESIGN

Designed according to IPF standards. It includes a safety set to protect torso and face, and a set of levers to regulate the height of the loaded barbell.

# BENCHES



CH-B10

## DECLINE BENCH PRESS

89 KG  
182 cm x 124 cm x 129 cm

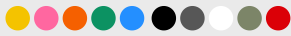

CH-B12

## VERTICAL BENCH PRESS

71 KG  
113 cm x 124 cm x 149 cm



CH-B16

## BENCH PRESS - COMPETITION

84 KG  
137 cm x 127 cm x 100 cm



CH-B14

## BENCH PRESS - UNIVERSAL

89 KG  
166 cm x 125 cm x 145 cm

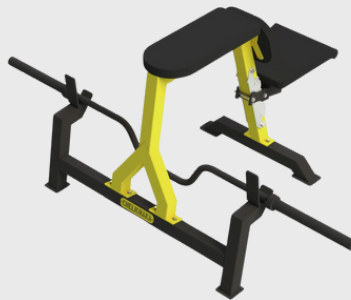
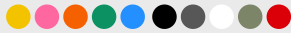

CH-B19

## ROW BENCH

42 KG  
127 cm x 135 cm x 92 cm

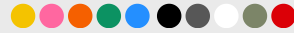

CH-B13

## COMBO BENCH

139 KG  
167 cm x 202 cm x 175 cm





3 barbell positions



Ergonomic leg pads

# OLYMPIC DECLINE BENCH

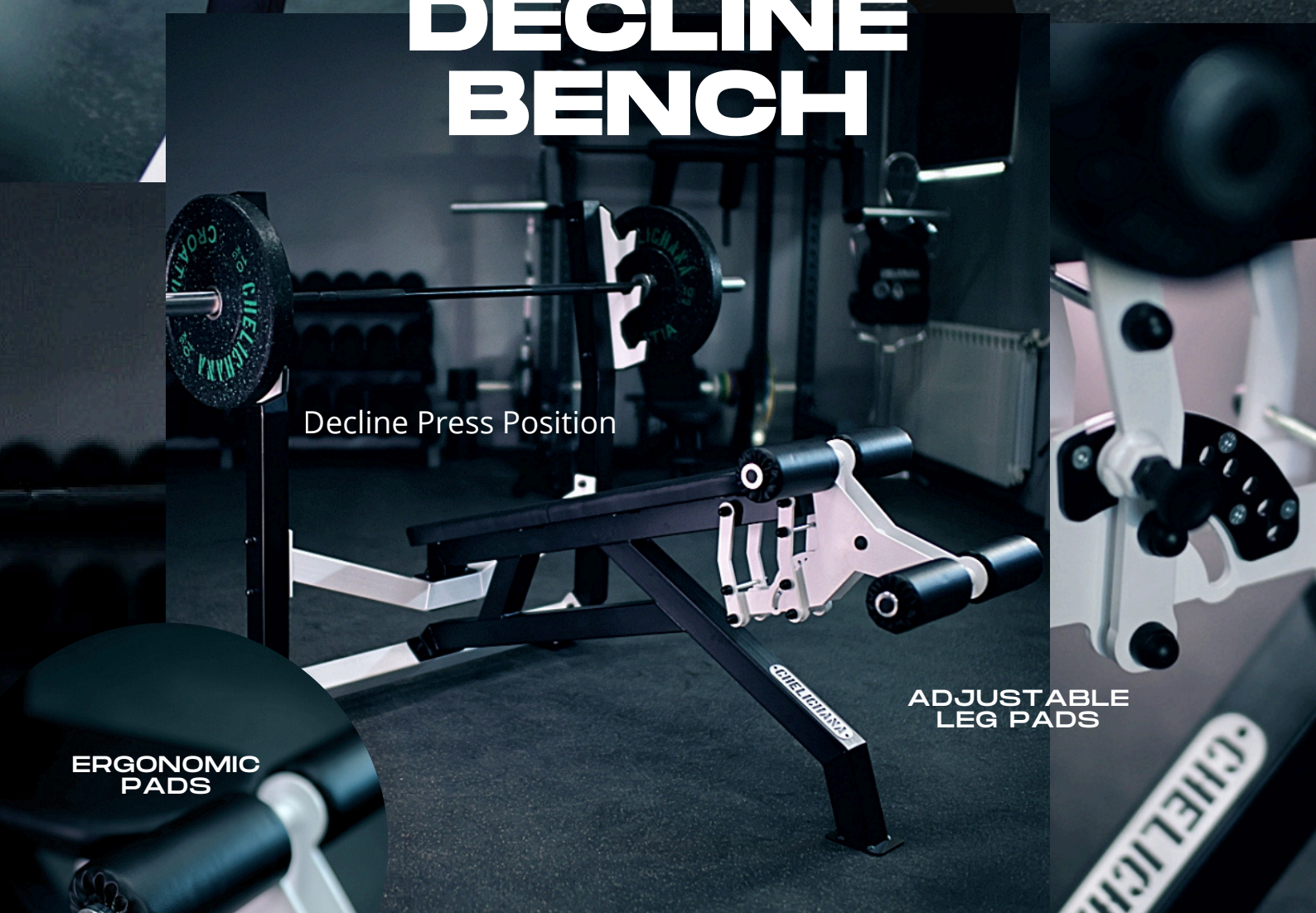

Decline Press Position

ADJUSTABLE  
LEG PADS



ERGONOMIC  
PADS

Allows users to perform decline pressing without excessive external rotation of the shoulders. The fixed angle of the seat pad provides correct positioning, and the adjustable leg roller pad ensure maximum adaptability for users of different sizes

UNLOCK THE FULL POTENTIAL OF YOUR TRAINING WITH OUR  
MULTIFUNCTIONAL CAGES THAT BRINGS TOGETHER STRENGTH, STABILITY,  
AND VERSATILITY, GIVING YOU A COMPLETE WORKOUT STATIONS  
DESIGNED TO SUPPORT EVERY LIFT, EVERY PULL, AND EVERY NEW  
PERSONAL BEST.

# CAGES



# CAGES



CH-K01

## ADJUSTABLE STANDS

25 KG  
65 cm x 55 cm x 120 cm

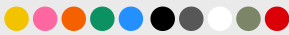

CH-K02

## MINI RACK

50 KG  
121 cm x 122 cm x 175 cm



CH-K03

## MEDIUM RACK

61 KG  
122 cm x 122 cm x 239 cm



CH-K04

## POWER RACK

99 KG  
94 cm x 122 cm x 233 cm



CH-K05

## POWER CAGE

115 KG  
142 cm x 122 cm x 239 cm

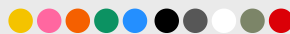

CH-K06

## HALF RACK

105 KG  
150 cm x 182 cm x 239 cm



CH-K07

## FOLDABLE RACK

57 KG  
61 cm x 122 cm x 233 cm



CH-K08

## MONSTER RACK

166 KG  
168 cm x 185 cm x 233 cm



CH-K09

## DOUBLE POWER CAGE

193 KG  
283 cm x 185 cm x 239 cm



Perfect for both home gyms and commercial spaces, our power cage provide a stable and secure foundation for your weightlifting routine.

# POWER CAGE

DESIGNED TO BE  
CUSTOMISED



multiple grip options

You can easily add attachments to expand your range of exercises, whether it's for dips, pull-ups, or landmine workouts.

custom nameplate logo

J-cups included

multiple laser-cut, numbered holes

with weight storage horns

made from high-grade steel



Our modular designs ensure that your power cage can evolve with your training, offering you the flexibility to grow as your fitness goals change

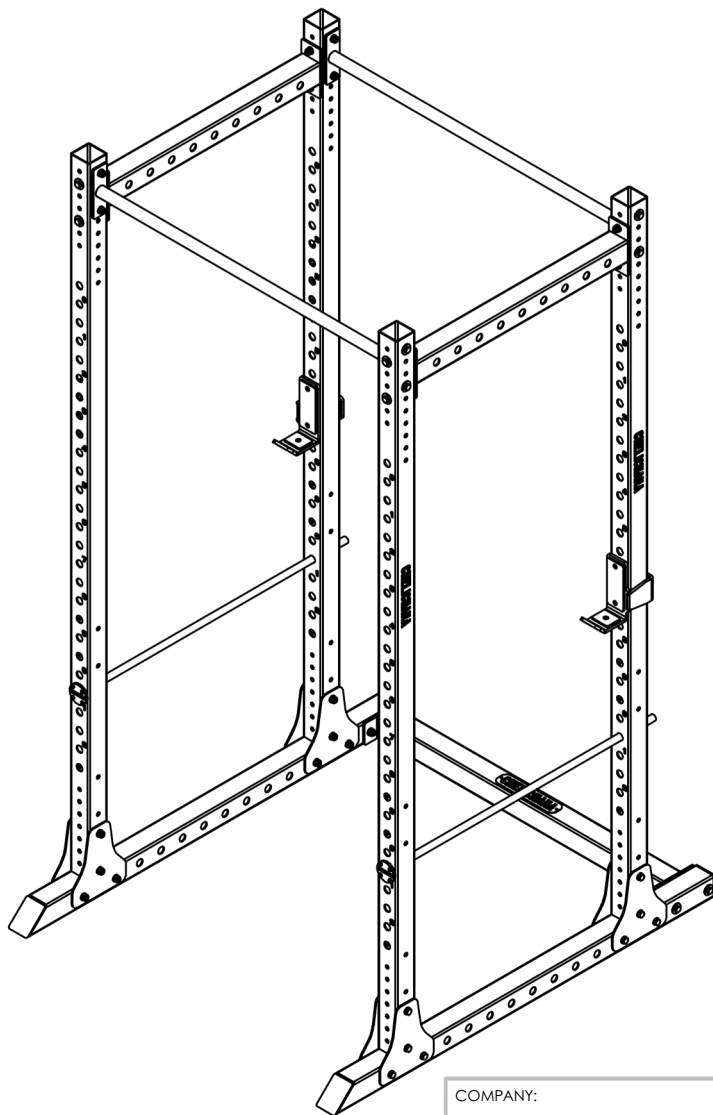
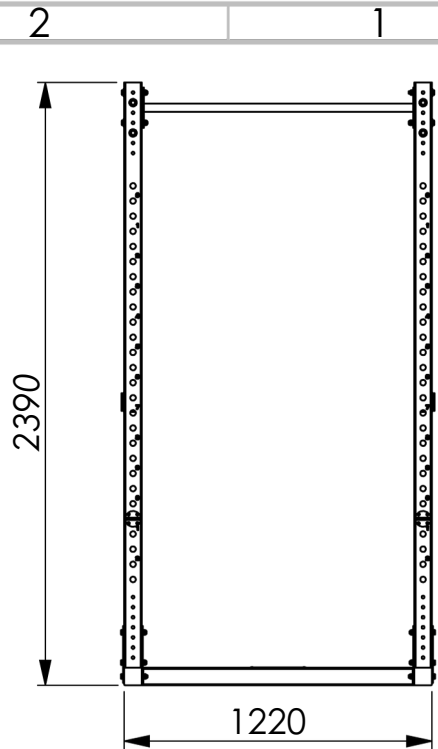
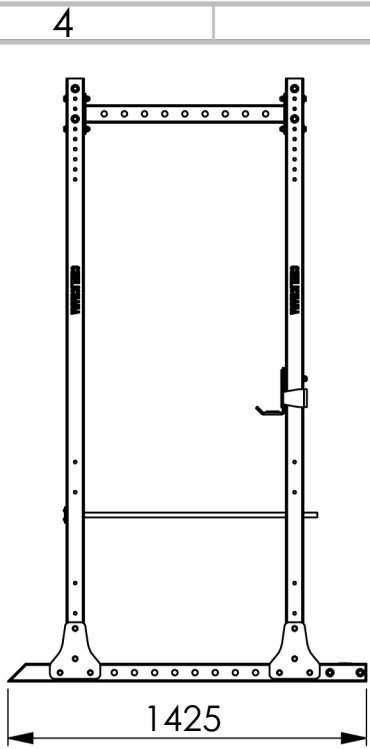

COMPANY:

**CHELICHANA**

PRODUCT:

K05 Power\_Cage

A4

SHEET 1 OF 1

# CAGES



CH-K33

## ULTIMATE CAGE

159 KG  
142 cm x 122 cm x 239 cm

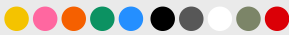

CH-K10

## WALL RACK WR2

49 KG  
115 cm x 122 cm x 272 cm



CH-K11

## WALL RACK WR3

80 KG  
115 cm x 289 cm x 272 cm



CH-K12

## WALL RACK WR4

108 KG  
115 cm x 404 cm x 272 cm

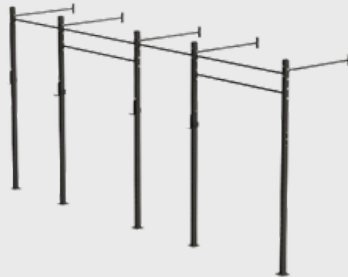

CH-K13

## WALL RACK WR5

139 KG  
115 cm x 571 cm x 272 cm

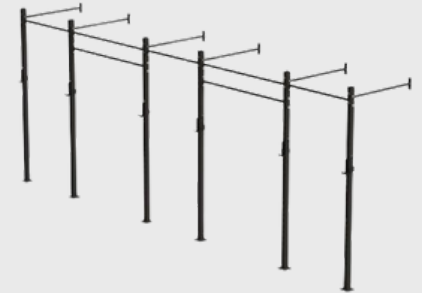

CH-K14

## WALL RACK WR6

169 KG  
115 cm x 686 cm x 272 cm



CH-K15

## SELF STANDING RACK

93 KG  
122 cm x 122 cm x 272 cm



CH-K16

## SELF STANDING RACK SR6

141 KG  
122 cm x 289 cm x 272 cm

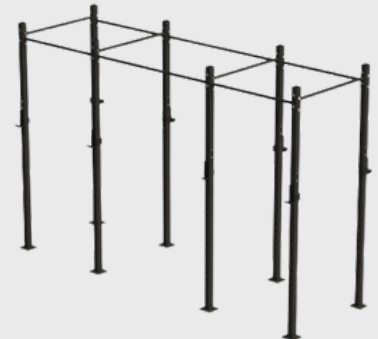

CH-K17

## SELF STANDING RACK SR8

195 KG  
122 cm x 404 cm x 272 cm

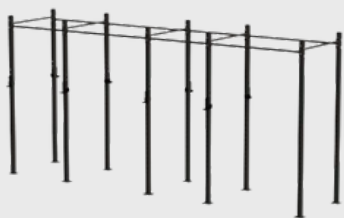

CH-K18

## SELF STANDING RACK SR10

245 KG  
122 cm x 571 cm x 272 cm



CH-K19

## SELF STANDING RACK SR12

298 KG  
122 cm x 686 cm x 272 cm



CH-K29

## GORILLA RACK

449 KG  
747 cm x 122 cm x 272 cm



CH-K30

## COMPETITON RIG

494 KG  
413 cm x 131 cm x 372 cm



OPTIMIZE YOUR WORKOUT SPACE WITH CAGE ATTACHMENTS.  
OUR VERSATILE ATTACHMENTS ARE DESIGNED AS AN UPGRADE TO YOUR  
EXISTING EQUIPMENT, ALLOWING YOU TO TAILOR YOUR WORKOUTS TO  
MEET YOUR SPECIFIC GOALS. FROM DIP BARS TO SAFETY ARMS,  
CHELICHANA CAGE ACCESSORIES PROVIDE THE TOOLS YOU NEED TO PUSH  
YOUR LIMITS SAFELY AND EFFECTIVELY.

# CAGE ATTACHMENTS





CH-A01

## J CUPS

5 KG  
18 cm x 8 cm x 19 cm



CH-A02

## MONSTER CUPS

6 KG  
18 cm x 8 cm x 19 cm



CH-A03

## DIPS 2.0

8 KG  
82 cm x 59 cm x 23 cm

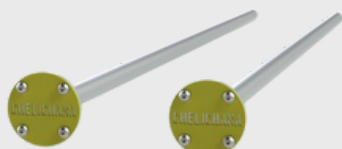

CH-A05

## SAFETY BARS

6 KG  
110 cm x 6 cm x 6 cm



CH-A08

## SAFETY STRAPS

4 KG  
115 cm x 15 cm x 15 cm



CH-A04

## NECK TRAINER

8 KG  
82 cm x 59 cm x 23 cm

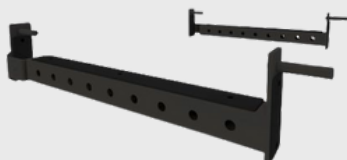

CH-A06

## SAFETY PROFILES

16 KG  
93 cm x 8 cm x 20 cm



CH-A07

## SPOTTER ARMS 2.0

17 KG  
69 cm x 8 cm x 30 cm

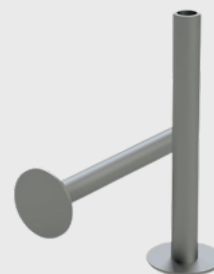

CH-A09

## BAND PINS

1 KG  
20 cm x 6 cm x 6 cm





CH-A17

## PLATES STORAGE BEHIND THE RACK

16 KG  
43 cm x 49 cm x 40 cm



CH-A11

## WALLBALL TARGET

9 KG  
77 cm x 10 cm x 35 cm



CH-A12

## BELT SQUAT ATTACHMENT

20 KG  
129 cm x 80 cm x 40 cm



CH-A13

## MONOLIFT ATTACHMENT

18 KG  
60 cm x 35 cm x 16 cm



CH-A17

## GRIP BALL

2 KG  
16 cm x 8 cm x 12 cm



CH-A19

## VERTICAL BARBELL HOLDER

2 KG  
10 cm x 6 cm x 31 cm



CH-A20

## LANDMINE 2.0

3 KG  
10 cm x 30 cm x 16 cm



CH-A21

## SELF-ALIGNING LND HANDLE

4 KG  
20 cm x 20 cm x 22 cm



CH-A22

## NARROW GRIP LND HANDLE

4 KG  
21 cm x 29 cm x 25 cm



CH-A23

**SINGLE HAND LND HANDLE**

1 KG  
22 cm x 6 cm x 20 cm



CH-A24

**WIDE GRIP LND HANDLE**

3 KG  
87 cm x 12 cm x 7 cm

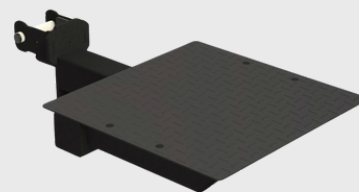

CH-A25

**STEP UP PLATFORM**

14 KG  
69 cm x 43 cm x 23 cm



CH-A26

**MULTIGRIP CHIN-UP CROSSMEMBER**

12 KG  
24 cm x 118 cm x 21 cm



CH-A28

**ROLLER PAD**

6 KG  
50 cm x 10 cm x 20 cm



CH-A29

**NAMEPLATE CROSSMEMBER**

13 KG  
108 cm x 7 cm x 36 cm



CH-A30

**GRIP BALL M20**

1 KG  
7 cm x 7 cm x 16 cm

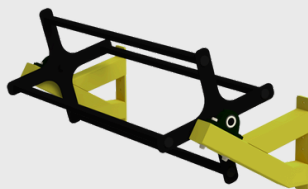

CH-A32

**REVOLVING PULL UP BAR**

26 KG  
55 cm x 122 cm x 57 cm

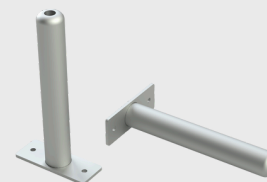

CH-A33

**PLATE HORNS**

3 KG  
6 cm x 16 cm x 35 cm

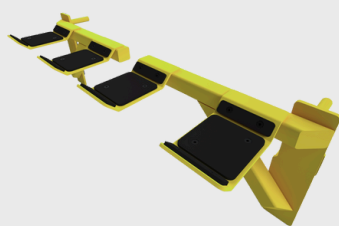

CH-A34

## DUMBBELL HOLDERS

15 KG  
32 cm x 45 cm x 31 cm



CH-A35

## RACK FIXING ATTACHMENT

6 KG  
7 cm x 108 cm x 10 cm



CH-A36

## RING + ROPE RACK EXTENSION

9 KG  
110 cm x 24 cm x 7 cm



CH-A37

## SHACKLE

1 KG  
7 cm x 8 cm x 17 cm

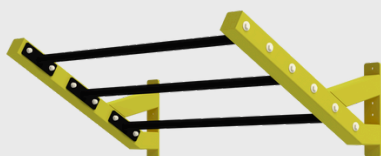

CH-A38

## RACK WING

26 KG  
63 cm x 122 cm x 46 cm



CH-A40

## ROLLER CUPS

5 KG  
17 cm x 9 cm x 22 cm



CH-A41

## JAMMER ARMS 2

35 KG  
104 cm x 72 cm x 30 cm



CH-A42

## RACK WEIGHT - VERTICAL

4 KG  
35 cm x 15 cm x 8 cm



CH-A47

## HIPTHRUST ATTACHMENT

5 KG  
133 cm x 23 cm x 11 cm

OUR STORAGE HELP YOU KEEP ALL OF YOUR WEIGHTS AND OTHER FITNESS EQUIPMENT ORGANIZED AND ACCESSIBLE. WITH A STORAGE, YOU CAN HAVE EVERYTHING YOU NEED FOR YOUR WORKOUT LAID OUT AND EASILY ACCESSIBLE, WHICH MAKES IT MUCH EASIER TO STAY ON TOP OF YOUR FITNESS ROUTINE.

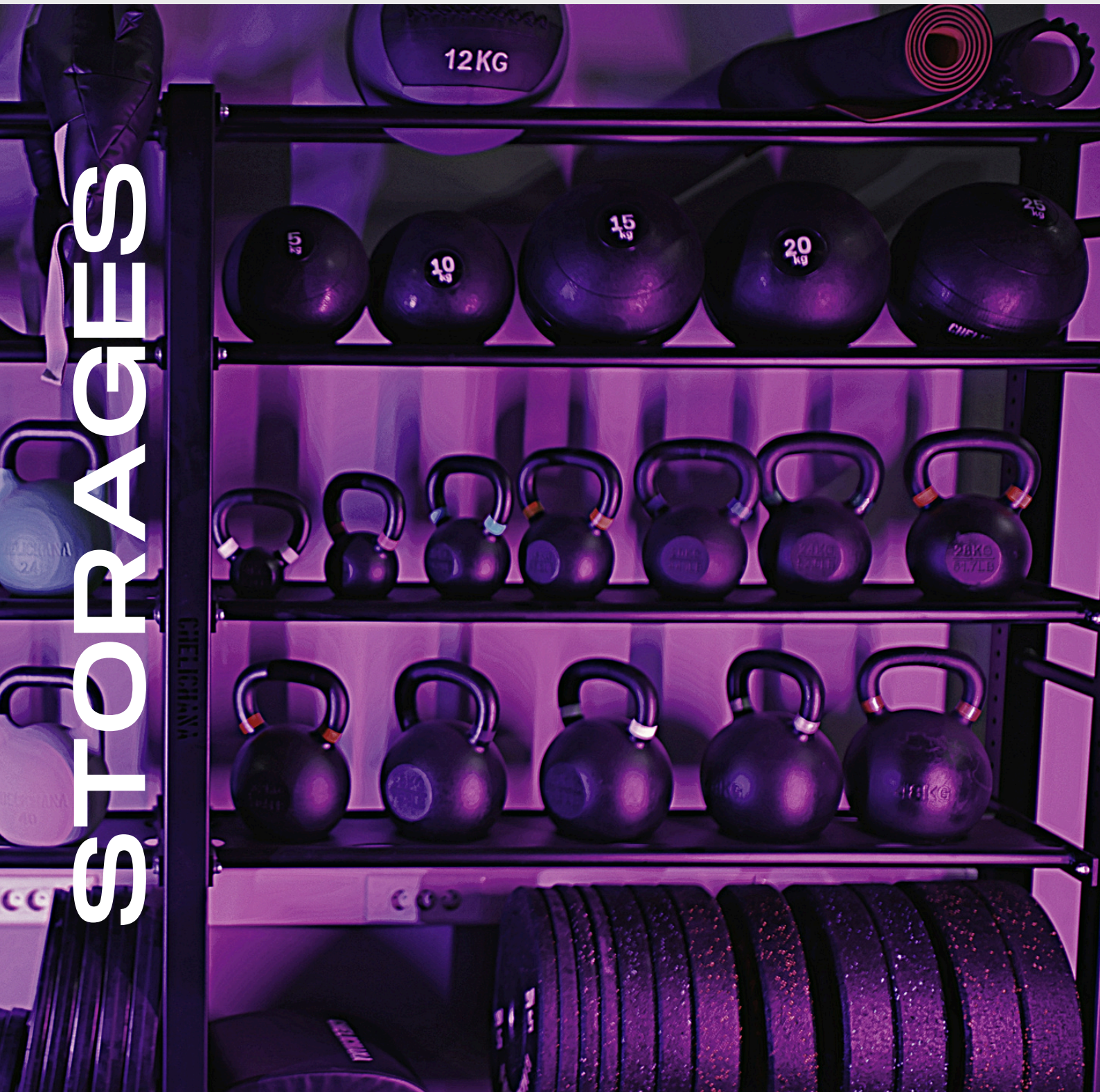

# STORAGES

# STORAGES



CH-S01

## WEIGHT TREE

32 KG  
67 cm x 66 cm x 135 cm



CH-S02

## BUMPER STACKER

19 KG  
138 cm x 41 cm x 33 cm

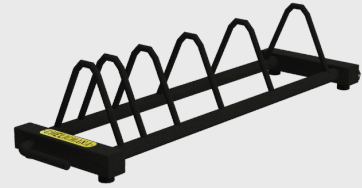

CH-S03

## BUMPER CART

19 KG  
146 cm x 41 cm x 33 cm

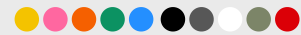

CH-S04

## WALL MOUNTED WEIGHT TREE

15 KG  
52 cm x 16 cm x 139 cm

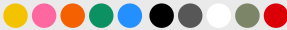

CH-S05

## WEIGHT TREE - ONE SIDED

22 KG  
45 cm x 62 cm x 133 cm



CH-S06

## HEX DUMBBELL STORAGE

79 KG  
71 cm x 135 cm x 83 cm



CH-S08

## UNIVERSAL STORAGE

35 KG  
54 cm x 122 cm x 132 cm



CH-S09

## KETTLEBELL STORAGE

69 KG  
71 cm x 138 cm x 80 cm



CH-S11

## BARBELL STORAGE (FLOOR)

19 KG  
52 cm x 80 cm x 36 cm



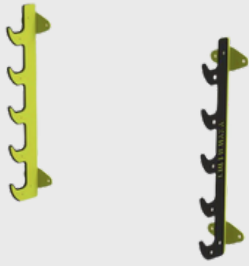

CH-S12

### BARBELL STORAGE (WALL MOUNTED)

7 KG  
15 cm x 16 cm x 75 cm

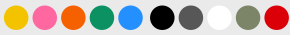

CH-S13

### CHIN UP

8 KG  
45 cm x 119 cm x 44 cm



CH-S14

### PULL UP

16 KG  
83 cm x 114 cm x 69 cm

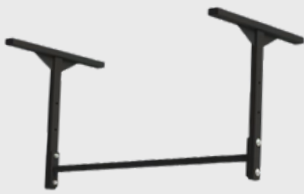

CH-S15

### CEILING PULL UP

13 KG  
61 cm x 116 cm x 64 cm



CH-S16

### MONKEY BAR

68 KG  
463 cm x 75 cm x 50 cm



CH-S17

### SWEDISH LADDER

75 KG  
43 cm x 132 cm x 246 cm



CH-S18

### BOXING BAG HANGER

13 KG  
100 cm x 83 cm x 53 cm



CH-S19

### CEILING BRACKET

1 KG  
20 cm x 20 cm x 6 cm



CH-S21

### HEX DUMBBELL 1-10 KG STORAGE

38 KG  
73 cm x 44 cm x 120 cm





CH-S22

### CEILING MOUNTED RING HANGER

5 KG  
7 cm x 90 cm x 9 cm



CH-S24

### CONCRETE BEAM MOUNTED CHIN UP

5.3 KG  
3 cm x 119 cm x 53 cm



CH-S25

### MINI PULL UP

9 KG  
40 cm x 100 cm x 36 cm

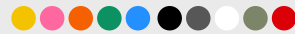

CH-S26

### WALLBALL STORAGE

14 KG  
47 cm x 116 cm x 36 cm

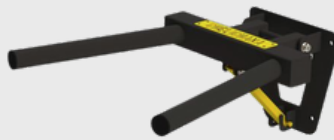
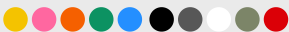

CH-S27

### DIPS FOLDABLE (WALL MOUNTED)

12 KG  
69 cm x 59 cm x 30 cm

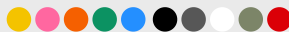

CH-S28

### DIPS FIX (WALL MOUNTED)

9 KG  
60 cm x 70 cm x 27 cm

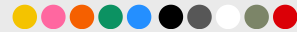

CH-S29

### WALL MOUNT JUMP ROPE HANGER

2 KG  
11 cm x 12 cm x 44 cm



CH-S30

### BUMPER LANDMINE

2.4 KG  
8 cm x 31 cm x 26 cm



CH-S31

### ECCENTRIC WEIGHT RELEASERS

12 KG  
32 cm x 13 cm x 78 cm



CH-S32

## VERTICAL BARBELL HOLDER

2 KG  
11 cm x 33 cm x 7 cm



CH-S34

## BARBELL BOX (9PCS)

31 KG  
60 cm x 60 cm x 29 cm



WHEN WE SAY WEIGHT PLATES, MOST PEOPLE THINK OF ONLY ONE EXERCISE: LIFTING. HOWEVER, IT'S THE SIMPLICITY THAT MAKES A WEIGHT PLATE SUCH A FLEXIBLE PIECE OF EQUIPMENT. AMONG OTHERS, YOU CAN USE IT TO BUILD ENDURANCE, BOOST STRENGTH, AND IMPROVE YOUR BALANCE.

# WEIGHTS



# WEIGHTS



CH-EBSET

## ELITE BUMPER PLATE SET

140 KG  
45 cm x 45 cm x 3 cm



CH-GUSET155

## SEVEN HOLE PLATE SET 155 KG

155 KG  
45 cm x 45 cm x 45 cm



CH-CRSET

## CRUMBRUBBER BUMPER SET 150KG

150 KG  
45 cm x 45 cm x 45 cm

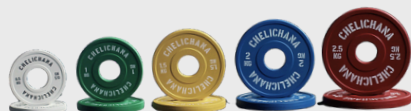

CH-MICR15

## MINI WEIGHT PLATES SET 0,5-2,5 KG

15 KG  
20 cm x 20 cm x 10 cm



CH-MICU5

## MICRO WEIGHT PLATE SET 0,25 -1 KG

5 KG  
15 cm x 15 cm x 5 cm



CH-MINU25

## CHANGE PLATES 0,5 - 5 KG

25 KG  
25 cm x 25 cm x 10 cm



CH-MINU15

## CHANGE PLATES 0,5 - 2,5 KG

15 KG  
25 cm x 25 cm x 10 cm



CH-S30

## TECHNIQUE PLATES 2.5 KG

5 KG  
45 cm x 45 cm x 5 cm



CH-S31

## TECHNIQUE PLATES 5 KG

10 KG  
45 cm x 45 cm x 10 cm

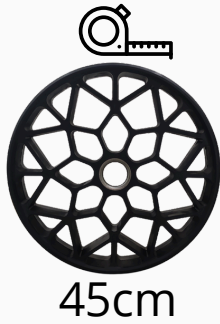

At a diameter of 450mm, our plates offer the perfect balance between size and weight. The lightweight construction allows you to focus on your form without compromising on durability. By reducing the load, you can work on your pulling technique, refine your bar path, and concentrate on overhead positions with greater precision.

# Improve your technique with style

TECHNIQUE PLATE



Designed specifically for Olympic weightlifting technique training, these plates are the ultimate choice for achieving technical perfection, preventing injuries, and facilitating rehabilitation.

# WEIGHTS



CH-CR5

## CRUMBRUBBER BUMPER 5KG

5 KG  
45 cm x 45 cm x 3 cm



CH-CR10

## CRUMBRUBBER BUMPER 10KG

10 KG  
45 cm x 45 cm x 45 cm



CH-CR15

## CRUMBRUBBER BUMPER 15KG

15 KG  
45 cm x 45 cm x 45 cm



CH-CR20

## CRUMBRUBBER BUMPER 20KG

15 KG  
20 cm x 20 cm x 10 cm



CH-CR25

## CRUMBRUBBER BUMPER 25KG

5 KG  
15 cm x 15 cm x 5 cm



CH-PP05

## POWERLIFTING PLATE 5KG

5 KG  
23 cm x 23 cm x 1.8 cm



CH-PP10

## POWERLIFTING PLATE 10KG

10 KG  
32.5 cm x 32.5 cm x 1.8 cm



CH-PP15

## POWERLIFTING PLATE 15KG

15 KG  
45 cm x 45 cm x 1.8 cm



CH-PP20

## POWERLIFTING PLATE 20KG

20 KG  
45 cm x 45 cm x 2 cm

# WEIGHTS



CH-PP25

## POWERLIFTING PLATE 25KG

25 KG  
45 cm x 45 cm x 2.4 cm



CH-PB5

## PREMIUM BUMPER 5KG

5 KG  
45 cm x 45 cm x 3 cm



CH-PB10

## PREMIUM BUMPER 10KG

10 KG  
45 cm x 45 cm x 5 cm



CH-PB15

## PREMIUM BUMPER 15KG

15 KG  
45 X 45 X 8 cm



CH-PB20

## PREMIUM BUMPER 20KG

20 KG  
45 cm x 45 cm x 11 cm



CH-PB25

## PREMIUM BUMPER 25KG

25 KG  
45 X 45 X 14 cm



CH-GU2.5

## SEVEN-HOLE PLATE 2.5KG

2.5 KG  
25 cm x 25 cm x 3 cm



CH-GU5

## SEVEN-HOLE PLATE 5KG

5 KG  
30 cm x 30 cm x 3 cm



CH-GU10

## SEVEN-HOLE PLATE 10KG

10KG  
45 cm x 45 cm x 3 cm

# WEIGHTS



CH-GU15

## SEVEN-HOLE PLATE 15KG

15 KG  
45 cm x 45 cm x 3 cm



CH-GU20

## SEVEN-HOLE PLATE 20KG

20 KG  
45 cm x 45 cm x 5 cm



CH-GU25

## SEVEN-HOLE PLATE 25KG

25 KG  
45 cm x 45 cm x 5 cm

THE BARBELL IS AN ESSENTIAL PART OF ANY STRENGTH ROUTINE AND A PILLAR OF ANY HOME GYM. WHETHER YOU'RE DOING BENCH PRESSES, SQUATS, DEADLIFTS, OR CURLS, BARBELLS ARE A CRITICAL TOOL FOR GETTING RESULTS.

# BARBELLS

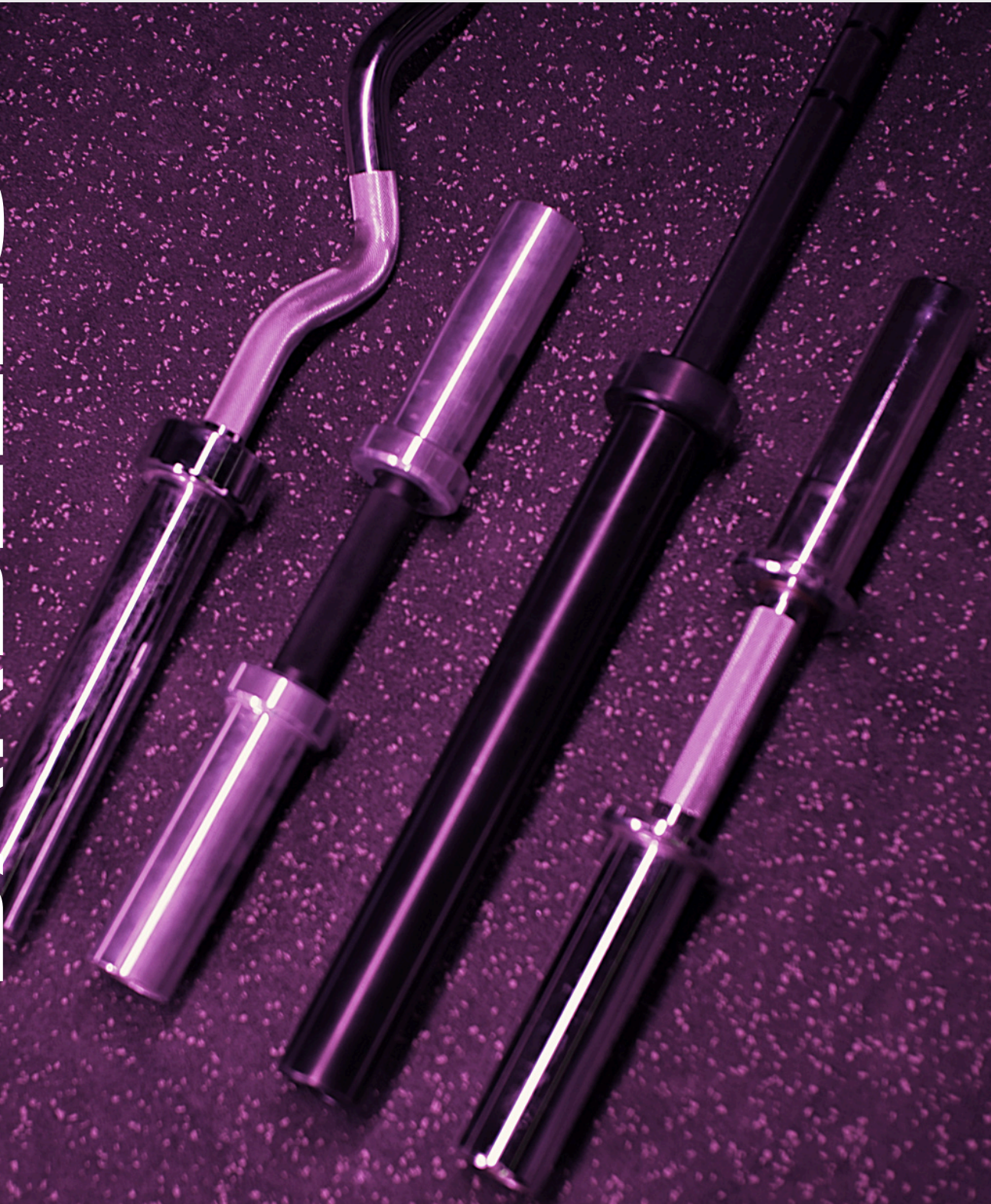

# BARS

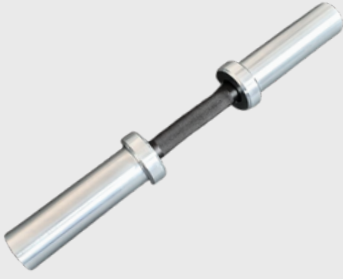

CH-BA0

## DUMBBELL BARBELL

6 KG  
50 cm x 7 cm x 7 cm



CH-BA2A

## EZ CURL BAR 120CM

8 KG  
120 cm x 8 cm x 8 cm



CH-BA3

## SHORT BARBELL

14 KG  
180 cm x 8 cm x 8 cm



CH-BA4

## ALUMINUM BAR

8 KG  
180 cm x 8 cm x 8 cm



CH-BA5

## TRAINING BAR BLACK

20 KG  
220 cm x 8 cm x 8 cm



CH-BA6

## PERFORMANCE BARBELL 15KG

15KG  
201 cm x 8 cm x 8 cm



CH-BA7

## PERFORMANCE BARBELL 20KG

20 KG  
220 cm x 8 cm x 8 cm



CH-BA8

## POWER BAR

20 KG  
220 cm x 8 cm x 8 cm



CH-BA9

## ELITE BARBELL 2.0

20 KG  
220 cm x 8 cm x 8 cm

# BARS

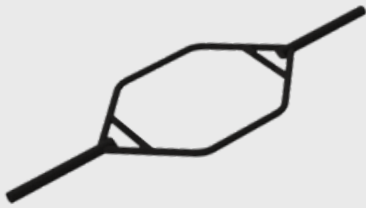

CH-Y01

## TRAP BAR SHORT

10 KG  
180 cm x 62 cm x 5 cm



CH-Y02

## TRAP BAR

15 KG  
219 cm x 69 cm x 7 cm



CH-Y03

## TRAP BAR 220CM DOUBLE HANDLES

17 KG  
220 cm x 69 cm x 14 cm



CH-Y04

## TRAP BAR 220 DOUBLE HANDLES ADJUSTABLE

20 KG  
220 cm x 72 cm x 36 cm



CH-Y20

## OPEN TRAP BAR

20 KG  
155 cm x 18 cm x 61 cm



CH-Y05

## SWISS BAR

17 KG  
220 cm x 27 cm x 7 cm



CH-Y06

## FOOTBALL BAR

17 KG  
220 cm x 27 cm x 7 cm



CH-Y07

## LOG BAR

45 KG  
200 cm x 33 cm x 33 cm



CH-Y08

## CAMBERED SWISS BAR

17 KG  
220 cm x 20 cm x 13 cm

# BARS



CH-Y22

## FOOTBALL PRESS BAR

12 KG  
220 cm x 20 cm x 7 cm

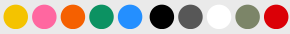

CH-Y10

## SAFETY SQUAT BAR 2.5

20 KG  
226 cm x 40 cm x 34 cm

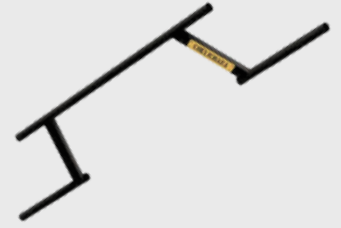

CH-Y11

## CAMBERED SQUAT BAR

12 KG  
220 cm x 7 cm x 55 cm

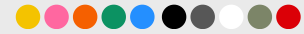

CH-Y12

## FARMERS WALK

38 KG  
169 cm x 41 cm x 12 cm



CH-Y13

## FARMERS HANDLES

7 KG  
47 cm x 20 cm x 43 cm



CH-Y17

## FAT BAR 50MM

8 KG  
220 cm x 7 cm x 7 cm



CH-Y21

## T-BELL WITH ROTATING HANDLES

5 KG  
50 cm x 20 cm x 20 cm



CH-Y23

## SUPERIOR BAR

23 KG  
242 cm x 47 cm x 29 cm



CH-Y30

## TIB BAR

4 KG  
29 cm x 15 cm x 32 cm



CH-OS4

## ALUMINUM COLLARS

0,5 KG  
9 X 9 X 5 cm



CH-OS1

## FLIP LOCK COLLARS

0,5 KG  
9 x 9 x 5 cm



CH-OS2

## SPRING COLLARS

0,5 KG  
19 x 13 x 5 cm

FROM BUILDING STRENGTH AND TONING YOUR MUSCLES TO IMPROVING YOUR BALANCE AND STABILITY, THEY'RE A FANTASTIC WORKOUT TOOL THAT CAN HELP YOU TAKE YOUR FITNESS TO NEXT LEVEL. DUMBBELLS ARE VERSATILE AND CAN BE USED TO TARGET A WIDE RANGE OF MUSCLE GROUPS.

# DUMBBELLS



# DUMBBELLS

WITH STORAGE



CH-HEX120B

## 2-20 HEX DUMBBELL SET

235 KG  
71 cm x 135 cm x 83 cm

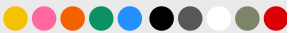

WITH STORAGE

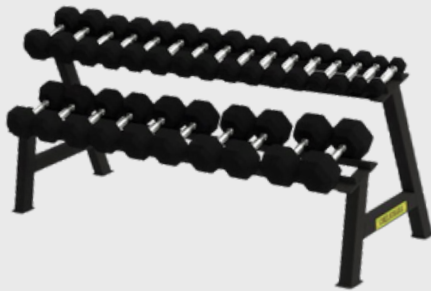

CH-HEX400B

## 2-30 HEX DUMBBELL SET

453 KG  
71 cm x 213 cm x 83 cm

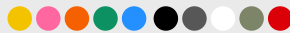

WITH STORAGE



CH-HEX690B

## 2-40 HEX DUMBBELL SET

767 KG  
71 cm x 291 cm x 83 cm



CH-HEX110B

## 1-10 HEX DUMBBELL SET

149 KG  
73 cm x 44 cm x 120 cm



CH-LD175

## LONG DUMBBELL SET

255 KG  
83 cm x 104 cm x 152 cm



CH-EDset180

## ELITE DUMBBELL 2.5-20 KG

235 KG  
71 cm x 135 cm x 83 cm

WITH STORAGE



CH-EDset390

## ELITE DUMBBELL SET 2.5-30 KG

453 KG  
71 cm x 213 cm x 83 cm

WITH STORAGE



CH-EDset680

## ELITE DUMBBELL SET 2.5-40 KG

767 KG  
71 cm x 291 cm x 83 cm

WITH STORAGE



CH-EDset1080

## ELITE DUMBBELL SET 2.5-50 KG

989 KG  
71 cm x 378 cm x 83 cm

OFTEN SEEN AS AN ESSENTIAL FUNCTIONAL FITNESS TOOL IN MANY GYMS, KETTLEBELLS OFFER EXTREME VERSATILITY AND A NICE BALANCE BETWEEN STRENGTH TRAINING AND CARDIOVASCULAR EXERCISE. USE THEM FOR ANYTHING FROM LUNGES AND GOBLET SQUATS TO PRESSES AND UNILATERAL WORK, EVEN MOBILITY TRAINING.

# KETTLEBELLS



# KETTLEBELLS



CH-CG8

## ELITE KETTLEBELL 8KG

8 KG  
29 x 29 x 20 cm



CH-CG12

## ELITE KETTLEBELL 12KG

12 KG  
29 x 29 x 20 cm



CH-CG16

## ELITE KETTLEBELL 16KG

16 KG  
29 x 29 x 20 cm



CH-CG20

## ELITE KETTLEBELL 20KG

20 KG  
29 x 29 x 20 cm



CH-CG24

## ELITE KETTLEBELL 24KG

24 KG  
29 x 29 x 20 cm



CH-CG28

## ELITE KETTLEBELL 28KG

28 KG  
29 x 29 x 20 cm



CH-CG32

## ELITE KETTLEBELL 32KG

32 KG  
29 x 29 x 20 cm



CH-CG36

## ELITE KETTLEBELL 36KG

36 KG  
29 x 29 x 20 cm



CH-CG40

## ELITE KETTLEBELL 40KG

40 KG  
29 x 29 x 20 cm

# KETTLEBELLS



CH-EG4

## EVOLUTION KETTLEBELL 4KG

4 KG  
16 x 7 x 17,5 cm



CH-EG8

## EVOLUTION KETTLEBELL 8KG

8 KG  
18 x 10 x 20 cm

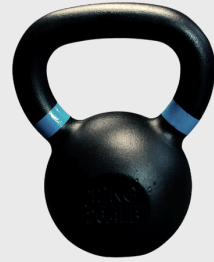

CH-EG12

## EVOLUTION KETTLEBELL 12KG

12 KG  
19 x 12 x 23 cm

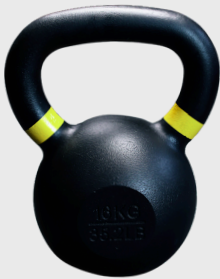

CH-EG16

## EVOLUTION KETTLEBELL 16KG

16 KG  
20 x 14 x 24 cm



CH-EG20

## EVOLUTION KETTLEBELL 20KG

20 KG  
20 x 15 x 25 cm



CH-EG24

## EVOLUTION KETTLEBELL 24KG

24 KG  
21 x 16 x 26 cm



CH-EG30

## EVOLUTION KETTLEBELL 28KG

28 KG  
21 x 17 x 27 cm



CH-EG32

## EVOLUTION KETTLEBELL 32KG

32 KG  
21 x 18 x 27 cm



CH-EG36

## EVOLUTION KETTLEBELL 36KG

36 KG  
21 x 19 x 27 cm

# KETTLEBELLS



CH-EG40

## EVOLUTION KETTLEBELL 40KG

40 KG  
21 x 20 x 28 cm



CH-EG44

## EVOLUTION KETTLEBELL 44KG

44 KG  
21 x 20 x 28 cm



CH-EG48

## EVOLUTION KETTLEBELL 48KG

48 KG  
21 x 21 x 28 cm



CH-MCB5

## MACEBELL 5KG

5 KG  
89,5 x 9 x 9 cm



CH-MCB10

## MACEBELL 10KG

10 KG  
112 x 12 x 12 cm



CH-MCB15

## MACEBELL 15KG

15 KG  
115 x 15 x 15 cm

OUR FUNCTIONAL PRODUCTS ARE DESIGNED TO ENHANCE ATHLETIC PERFORMANCE AND CHALLENGE YOUR BODY THROUGH A VARIETY OF MOVEMENTS, OFFERING VERSATILITY, EFFICIENCY, AND THE ABILITY TO TARGET MULTIPLE MUSCLE GROUPS.

# FUNCTIONAL EQUIPMENT





CH-ABM

### ABMAT

1 KG  
30 cm x 30 cm x 6 cm



CH-VEST

### WEIGHT VEST

2 KG  
40 cm x 40 cm x 10 cm



CH-BELT

### LIFTING BELT

1 KG  
40 x 30 x 20 cm



CH-CHGRT

### LIFTING STRAPS

0,5 KG  
7 x 5 x 5 cm



CH-ANGL

### ANKLE BUCKLE

1 KG  
10 cm x 10 cm x 10 cm



CH-HNDL

### CABLE ATTACHMENT

1 KG  
15 cm x 4 cm x 15 cm



CH-ANKS

### ANKLE STRAP

1 KG  
10 cm x 10 cm x 10cm



CH-KAR1

### GYM RING WOODEN

2 KG  
20 cm x 20 cm x 5 cm



CH-KAR2

### GYM RING PLASTIC

2 KG  
20 cm x 20 cm x 5 cm



CH-HAR

## PULLING HARNESS

2 KG  
30 cm x 30 cm x 6 cm



CH-BELT4

## SQUAT/DIP BELT

3 KG  
73 cm x 10 cm x 5 cm



CH-ABS

## AB SLINGS

1 KG  
50 cm x 20 cm x 10 cm



CH-BOX2

## JUMP BOX WOODEN

24 KG  
75 x 60 x 50 cm



CH-BOX1

## JUMP BOX SOFT

26.5 KG  
75 x 60 x 50 cm



CH-ROPE2

## ROPE 5M POLYESTER

5 KG  
60 cm x 30 cm x 20 cm



CH-ROPE1

## ROPE 5M

5 KG  
60 cm x 30 cm x 20 cm



CH-ROPE3

## BATTLE ROPE 12M

12 KG  
60 cm x 30 cm x 40 cm



CH-TRX

## SUSPENSION TRAINER

1 KG  
30 cm x 20 cm x 10 cm



CH-BLA

## BICEPS BLASTER

2 KG  
60 cm x 12 cm x 12 cm



CH-ROL

## ROLLER

1 KG  
35 x 15 x 15 cm



CH-ABW

## AB WHEEL

2 KG  
20 cm x 20 cm x 10 cm



CH-MAT1

## TPE YOGA MAT

149 KG  
73 cm x 44 cm x 120 cm



CH-BAG25

## BULGARIAN BAG 25KG

25 kg  
63 x 50 x 18 cm



CH-BAG20

## BULGARIAN BAG 20KG

20 kg  
63 x 50 x 18 cm



CH-BAG15

## BULGARIAN BAG 15KG

15 kg  
63 x 50 x 18 cm



CH-BAG10

## BULGARIAN BAG 10KG

10 kg  
63 x 50 x 18 cm



CH-BAG5

## BULGARIAN BAG 5KG

5 kg  
63 x 50 x 18 cm



CH-BAGSET

## BULGARIAN BAG SET

75 kg  
63 x 50 x 100 cm



CH-WB12

## WALL BALL 12 KG

12 kg  
30 x 30 x 30 cm



CH-WB9

## WALL BALL 9 KG

9 kg  
30 X 30 X 30 cm



CH-WB6

## WALL BALL 6 KG

6 kg  
30 x 30 x 30 cm



CH-WB4

## WALL BALL 4 KG

4 kg  
30 x 30 x 30 cm



CH-WBSET

## WALL BALL SET 4-6-9-12 KG

32 kg  
90 x 30 x 30 cm



CH-SLAM5

## SLAM BALL 5 KG

5 kg  
24 x 24 x 24 cm



CH-SLAM10

## SLAM BALL 10 KG

10 kg  
24 x 24 x 24 cm



CH-SLAM15

## SLAM BALL 15 KG

15 kg  
24 x 24 x 24 cm



CH-SLAM20

### SLAM BALL 20 KG

5 kg  
24 x 24 x 24 cm



CH-SLAM25

### SLAM BALL 25 KG

10 kg  
24 x 24 x 24 cm



CH-SLAMSET

### SLAM BALL SET 5-25KG

15 kg  
60 x 30 x 2 cm



CH-LASET

### RESISTANCE BAND SET 13-83MM

1 kg  
30 x 30 x 2 cm



CH-LA83

### RESISTANCE BAND 83MM

1 kg  
30 x 30 x 2 cm



CH-LA64

### RESISTANCE BAND 64MM

1 kg  
30 X 30 X 2 cm



CH-LA45

### RESISTANCE BAND 45MM

1 kg  
30 x 30 x 2 cm



CH-LA32

### RESISTANCE BAND 32MM

1 kg  
30 x 30 x 2 cm



CH-LA21

### RESISTANCE BAND 21MM

1 kg  
30 x 30 x 2 cm



CH-DROP

## DROP PADS

9 KG  
77 x 62 x 16 cm



CH-NBR

## YOGA MAT BLACK

1 kg  
160 x 60 x 4 cm



CH-JMP

## JUMPING ROPE BLACK

1 kg  
10 x 15 x 4 cm



CH-JMP2

## JUMPING ROPE ALUMINUM

9 KG  
77 x 62 x 16 cm



CH-Y25

## HUSSAFEL STONE

43 KG  
16 x 74 x 76 cm

Improve your heart health, boost your  
endurance and reach your weight loss goals  
with our cardio equipment

CARDIO



# CARDIO



CAR-06

## AIRBIKE

55 KG  
120 x 65 x 125 cm



CAR-07

## TREADMILL 1002B

175 KG  
200 x 90 x 156 cm



CAR-05

## AIRRUNNER

165 KG  
170 x 85 x 158 cm



CAR-02

## ERGOROW

30 KG  
240 X 62 X 105 cm

Create the workout area of your dreams with  
rubber and foam gym flooring, artificial  
turfs, poured rubber and more

# FLOORS

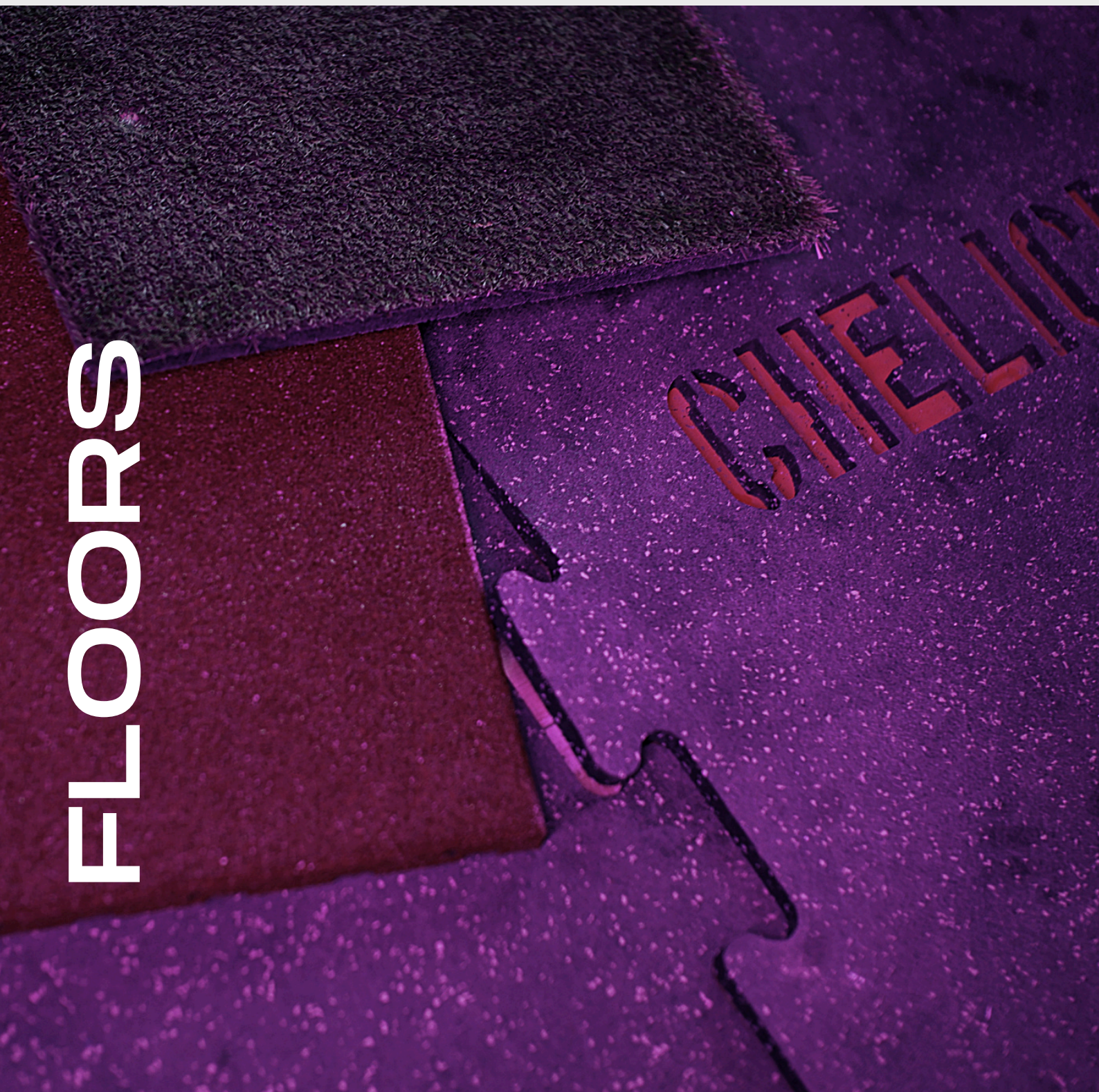

# FLOORS

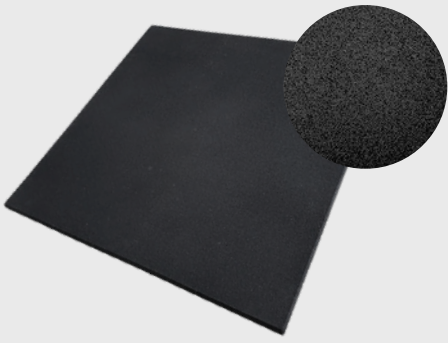

CH-RF20B

## RUBBER FLOOR

19 KG  
100 cm x 100 cm x 2 cm

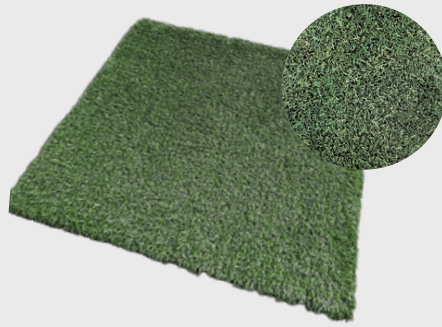

CH-GF20

## GREEN FLEX 20MM

6 KG  
50 cm x 50 cm x 2 cm



CH-PF30PF

## PLAYFLEX 40MM

7 KG  
50 cm x 50 cm x 3 cm



CH-RF10

## RUBBER FLOOR PUZZLE

10 KG  
100 cm x 100 cm x 1 cm



CH-RFH40

## RUBBER CLINKER H 40MM

1 KG  
10 cm x 10 cm x 10 cm



CH-GT12.5X2

## GREENTRACK 12.5 X 2M

60 KG  
1250 cm x 200 cm x 2 cm

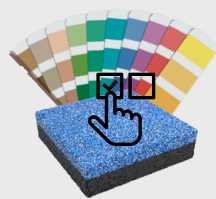

MULTIPLE COLOR  
OPTIONS



UV AND WEATHER  
RESISTANT



CH-RFX

## POURED RUBBER

200 KG  
1000 cm x 1000 cm x 2 cm

Unleash your inner fashion athlete with the chelichana apparel. Our high-performance pieces seamlessly blend elevated style and active functionality, empowering you to look and feel your best no matter the occasion.

# APPAREL



# APPAREL



CH-TSBLACK

## TSHIRT BLACK

S, M, L, XL



CH-TSGRAY

## TSHIRT GRAY

S, M, L, XL



CH-TSGREEN

## TSHIRT MILITARY

S, M, L, XL



CH-TSLIFT

## TSHIRT LIFT GREY

S, M, L, XL



CH-TSNAVY

## TSHIRT NAVY

S, M, L, XL



CH-TSORANGE

## TSHIRT ORANGE

S, M, L, XL



CH-LSBLACK

## LONG SLEEVE BLACK

S, M, L, XL



CH-LSGRAY

## LONG SLEEVE GRAY

S, M, L, XL



CH-HDGRAY

## HOODIE GRAY

S, M, L, XL

# APPAREL



CH-TSWHITE

## TSHIRT WHITE

S, M, L, XL



CH-TSPINK

## TSHIRT PINK

S, M, L, XL



CH-TSBLKKID

## TSHIRT KIDS BLACK

S, M, L, XL



CH-HDPINKKID

## HOODIE BABY PINK

S, M, L, XL



CH-HDBLKKID

## HOODIE BABY BLACK

S, M, L, XL



CH-HDBLUEKID

## HOODIE BABY BLUE

S, M, L, XL



CH-HDBLACK

## HOODIE BLACK

S, M, L, XL



CH-HDNAVY

## HOODIE NAVY

S, M, L, XL



CH-HDSAND

## HOODIE SAND

S, M, L, XL

Unlock your full potential and push your limits like never before. Our outdoor equipment is engineered to help you build strength, boost endurance, and achieve your wellness goals in an energizing open-air setting.



OUTDOOR

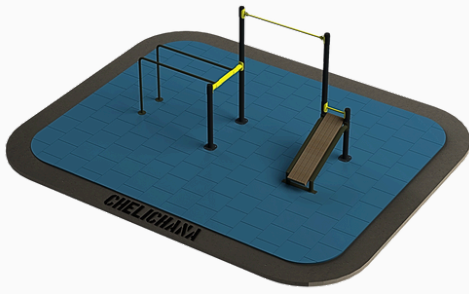

SW-CO1

## SW PARK XS

19 KG  
100 cm x 100 cm x 2 cm

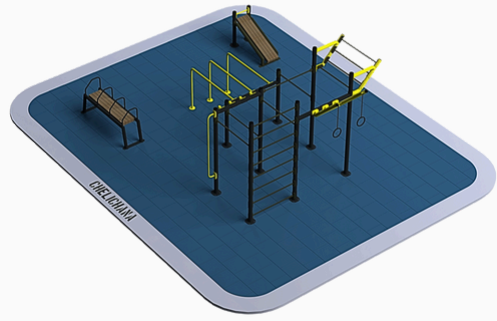

SW-CO2

## SW PARK S

6 KG  
500 cm x 500 cm x 20 cm

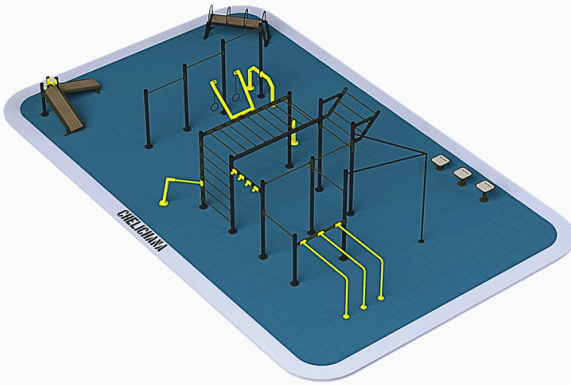

SW-CO3

## SW PARK M

19 KG  
100 cm x 100 cm x 2 cm

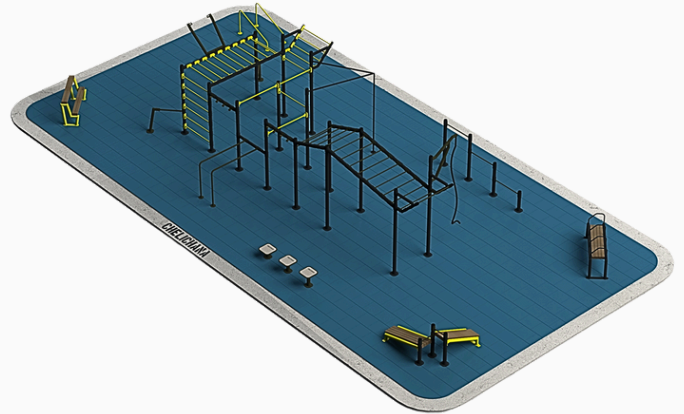

SW-CO4

## SW PARK L

6 KG  
500 cm x 500 cm x 20 cm

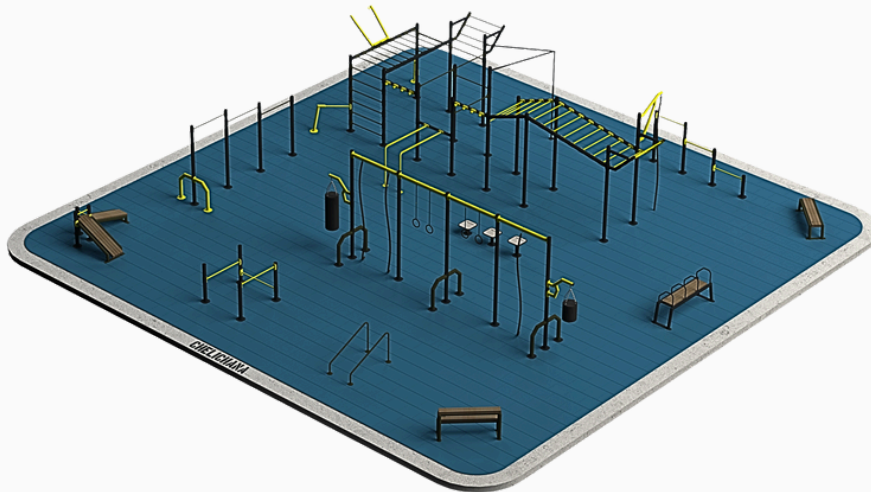

SW-CO5

## SW PARK XL

6 KG  
500 cm x 500 cm x 20 cm

# STREET WORKOUT

Street workout parks offer a multi-sensory experience, providing high-quality content for exercisers of all ages and fitness levels. We strive to make our workout areas more challenging and interactive, allowing both recreational users and professional athletes to continually discover new training challenges on our equipment.

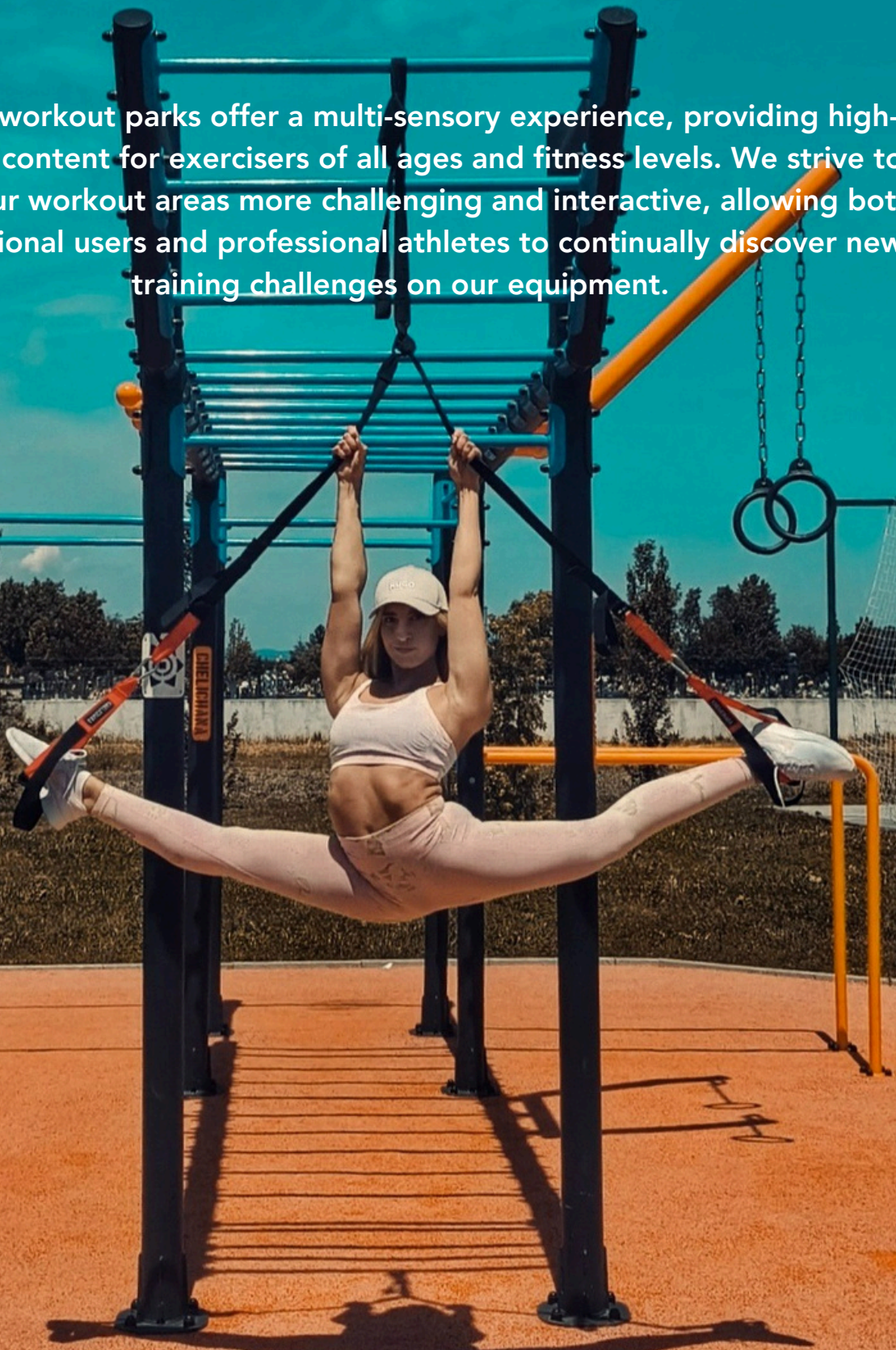

Our parks are manufactured and certified according to the standards: EN 16630, EN 1090, and EN 16899, ensuring they meet the highest global safety standards during use. In addition to offering opportunities for top-notch training, the parks encourage community engagement in an active and healthy lifestyle.

# OUTDOOR MACHINES

CHELICHANA

CHELICHANA

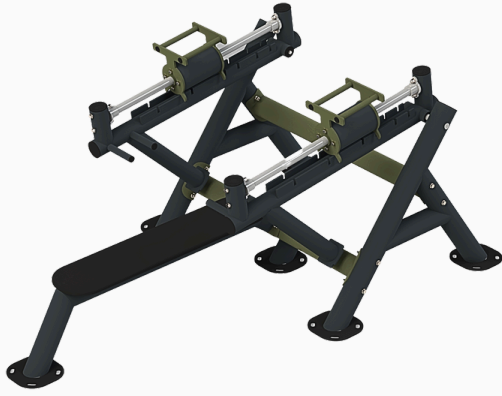

SW-C10

## BENCH PRESS

208 kg  
150 x 249 x 110 cm



SW-C11

## LEG PRESS

302 kg  
117 x 286 x 131 cm



SW-C12

## SHOULDER PRESS

217 kg  
139 x 163 x 161 cm



SW-C13

## SEATED ROW

214 kg  
134 x 211 x 97 cm



SW-C14

## LAT PULLDOWN

237 kg  
174 x 248 x 179 cm

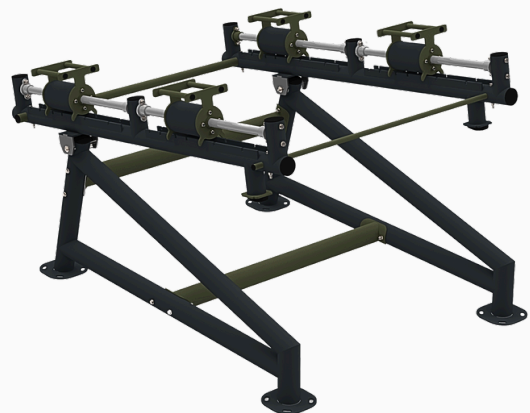

SW-C15

## DEADLIFT

332 kg  
168 x 232 x 135 cm

## UNIQUE WEIGHT SYSTEM

Its clever design allows weight plates to move securely and safely. Moving the weight increases and reduces the tension.

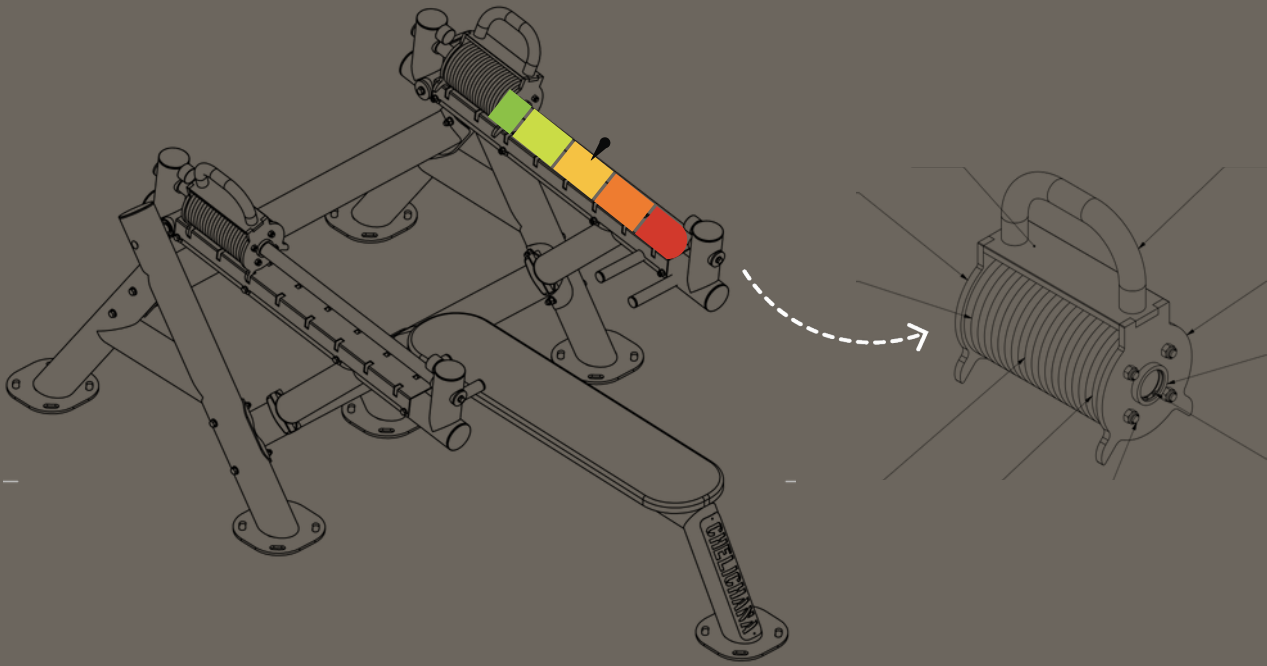

This system gives a far more natural feel (rather than the use of hydraulics) and is a fantastic progressive range for those users who are looking for that indoor gym feel.





SW-C16

## SQUAT

254 kg  
168 x 211 x 142 cm

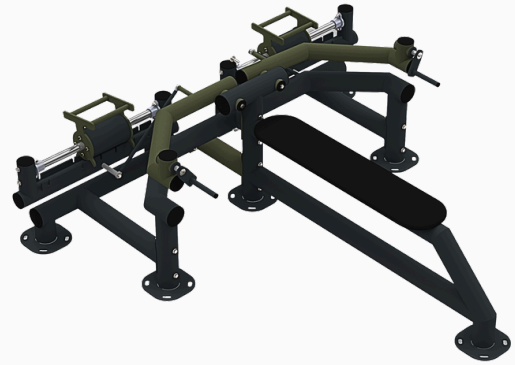

SW-C17

## BUTTERFLY

263 kg  
234 x 228 x 80 cm

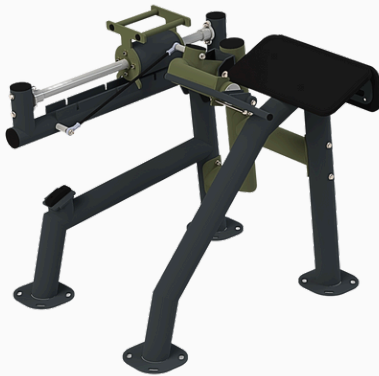

SW-C18

## BICEPS TRAINER

142 kg  
115 x 126 x 110 cm



SW-C19

## TRICEPS TRAINER

218 kg  
142 x 188 x 208 cm

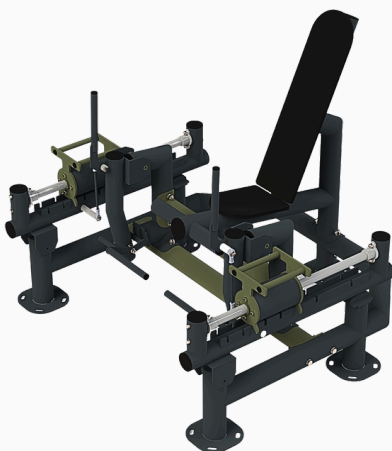

SW-C20

## LEG EXTENSION

277 kg  
164 x 159 x 147 cm



SW-C21

## GLUTE KICKBACK

232 kg 149 x 167 x  
179 cm



SW-C22

## CHEST PRESS

279 kg  
186 x 174 x 184 cm



SW-C23

## BACK HYPEREXTENSION

149 kg  
138 x 93 x 107 cm



SW-C24

## STANDING ROW

212 kg 131 x 149 x  
199 cm



SW-C50

### WOD BOX XS

411 KG  
143 x 298 x 280 cm



SW-C51

### WOD BOX S

486 KG  
143 X 456 X 280 cm



SW-C52

### WOD BOX M

683 KG  
529 X 337 X 280 cm

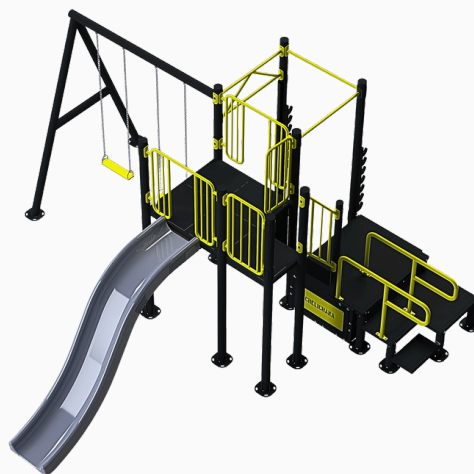

SW-C53

### WOD BOX L

700 KG  
529 x 573 x 280 cm

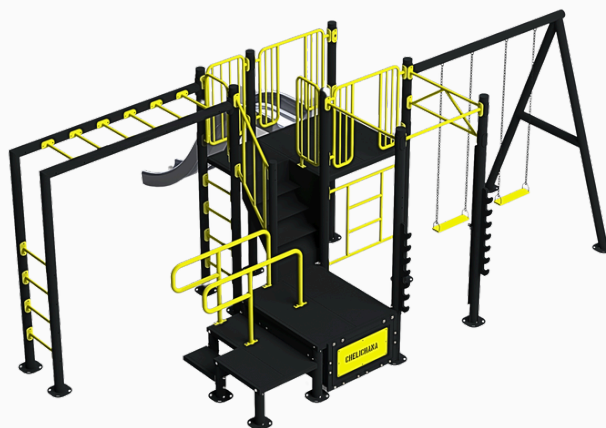

SW-C54

### WOD BOX XL

840 KG  
529 x 692 x 280 cm

THE ULTIMATE FUNCTIONAL OUTDOOR PLAYGROUND

PARALLEL  
DIP BARS

PULLUP  
BARS

PLAYGROUND  
SLIDE

MODULAR  
CLIMBING  
PLATFORM

PLAYGROUND  
SWING

PROTECTED  
BARBELL  
HOLDER

MONKEY  
BARS

INTEGRATED  
BARBELL  
STORAGE

INTEGRATED  
WEIGHTS  
STORAGE

WORD BOX



MULTIPLE COLOR  
OPTIONS



UV PROTECTED



PRACTICAL  
DESIGN



LONG LASTING  
HEAVY DUTY  
STEEL

# FORGE YOUR STRENGTH WITH US



[info@chelichana.hr](mailto:info@chelichana.hr)



[www.chelichana.hr](http://www.chelichana.hr)